

FLEXICODE

Operating Manual



Copyright by Carl Valentin GmbH / 7979005.0825

Information on the scope of delivery, appearance, performance, dimensions, and weight reflect our knowledge at the time of printing.

We reserve the rights to make modifications.

All rights, including those regarding the translation, are reserved.

No part of this document may be reproduced in any form (print, photocopy, or any other method) or edited, copied, or distributed electronically without written permission from Carl Valentin GmbH.

Due to the constant further development of our devices discrepancies between manual and device can occur.

Please check www.carl-valentin.de for the latest update.

Trademarks

All named brands or trademarks are registered brands or registered trademarks of their respective owners and may not be separately labelled. It must not be concluded from the missing labelling that it is not a registered brand or a registered trademark.

Carl Valentin direct print modules comply with the following EU directives:

CE Low-Voltage Directive (2014/35/EU)
Electromagnetic Compatibility Directive (2014/30/EU)



Carl Valentin GmbH

Neckarstraße 78 – 86 u. 94
78056 Villingen-Schwenningen

Phone +49 7720 9712-0
E-Mail info@carl-valentin.de
Internet www.carl-valentin.de

Table of Contents

1	Introduction.....	5
1.1	General Instructions	5
1.2	Intended Use	5
1.3	Safety Instructions	6
1.4	Decommissioning and Dismantling	7
2	Machine Overview	9
2.1	Figures.....	10
2.2	Continuous Mode	12
2.3	Intermittent Mode.....	13
3	Operating Conditions.....	15
4	Technical Data	19
4.1	Control Inputs and Outputs	21
4.2	Pin Assignment of Encoder Socket	30
5	Installation and Initial Operation.....	31
5.1	Install the Print Mechanics at Machines.....	32
5.2	Connect the Pneumatic Power Supply.....	34
5.3	Adjust the Pressure Power.....	35
5.4	Connect the Direct Print Module	36
5.5	Before Initial Operation.....	36
5.6	Print Control.....	37
5.7	Initial Operation	37
5.8	Load Transfer Ribbon.....	38
5.9	Increase the Clamping Force for Ribbon Roll	39
6	Operation Panel	41
6.1	Keyboard (Standard)	41
6.2	Keyboard (Text Entry/User Guiding)	42
7	Function Menu	45
7.1	Menu Structure (Continuous Mode)	45
7.2	Menu Structure (Intermittent Mode)	48
7.3	Print Settings	51
7.4	Machine Parameters (Continuous Mode).....	52
7.5	Machine Parameters (Intermittent Mode).....	54
7.6	Layout.....	56
7.7	Ribbon Save	57
7.8	Ribbon Save (Continuous Mode)	58
7.9	Ribbon Save (Intermittent Mode)	62
7.10	Device Settings.....	64
7.11	I/O Parameters	67
7.12	Network	68
7.13	Password.....	70
7.14	Interface.....	72
7.15	Emulation.....	73
7.16	Date & Time.....	74
7.17	Service Functions	75
7.18	Main Menu	78
7.19	Display During Printing.....	78
8	Compact Flash Card / USB Memory Stick	79
8.1	General Information.....	79
8.2	Display Structure	79
8.3	Navigation.....	80
8.4	Define User Directory	81
8.5	Load Layout.....	82
8.6	File Explorer	83
8.7	Firmware Update	88
8.8	Filter.....	88

9	Maintenance and Cleaning	89
9.1	General Cleaning.....	90
9.2	Clean the Transfer Ribbon Drawing Roller	90
9.3	Clean the Printhead.....	91
9.4	Replace the Printhead	92
9.5	Angle Adjustment (Intermittent Mode).....	94
9.6	Print Quality Optimisation	95
9.7	Cycle optimisation (Intermittent Mode).....	96
10	Signal Diagrams	97
10.1	Continuous Mode	97
10.2	Intermittent Mode.....	101
11	Error Correction.....	103
12	Additional Information	115
12.1	Column Printing	115
12.2	Hotstart	116
13	Environmentally-Friendly Disposal	119
14	Index	121

1 Introduction

1.1 General Instructions

Basic information and warning references with the corresponding signal words for the danger level are as follows specified in this manual:



DANGER identifies an extraordinarily great and immediate danger which could lead to serious injury or even death.



WARNING identifies a possible danger could lead to serious bodily injury or even death if sufficient precautions are not taken.



WARNING of cutting injuries.

Pay attention that cutting injuries caused by blades, cutting devices or sharp-edged parts are avoided.



WARNING of hand injuries.

Pay attention that hand injuries caused by closing mechanical parts of a machine/equipment are avoided.



WARNING of hot surfaces.

Pay attention so as not to come into contact with hot surfaces.



CAUTION indicates a potentially dangerous situation which could lead to moderate or light bodily injury or damage to property.



NOTICE gives you tips. They make a working sequence easier or draw attention to important working processes.



Gives you tips on protecting the environment.



Handling instruction



Optional accessories, special fittings

Datum

Information in the display

1.2 Intended Use

The direct print module is a state-of-the-art device which complies with the recognized safety-related rules and regulations. Despite this, a danger to life and limb of the user or third parties could arise and the direct print module or other property could be damaged while operating the device.

The direct print module may only be used while in proper working order and for the intended purpose. Users must be safe, aware of potential dangers and must comply with the operating instructions. Faults, in particular those which affect safety, must be remedied immediately.

The direct print module is solely intended to print suitable media which have been approved by the manufacturer. Any other or additional use is not intended. The manufacturer/supplier is not liable for damage resulting from misuse. Any misuse is at your own risk.

Intended used includes heeding the operating manual, including the maintenance recommendations/regulations specified by the manufacturer.

1.3 Safety Instructions

The direct print module is configured for a voltage of 200-240 V AC or 100-120 V AC (see type plate). It has to be plugged into a grounded socket only.

Couple the direct print module to devices using extra low voltage only.

Before making or undoing connections, switch off all devices involved (computer, printer, accessories etc.).

Operate the direct print module in a dry environment only and do not get it wet (sprayed water, mist etc.).

Do not operate the direct print module in explosive atmosphere and not in proximity of high voltage power lines.

Operate the direct print module only in an environment protected against abrasive dust, swarf and other similar impurity.

Maintenance and servicing work can only be carried out by trained personnel.

Operating personnel must be trained by the operator on the basis of the operating manual.

Depending on use, ensure that clothing, hair, jewellery and similar personal items do not contact the exposed rotating parts and/or the moving parts (e.g. print carriage).



NOTICE!

With the open printing unit (due to construction) the requirements of EN 62368-1 regarding fire protection casing are not fulfilled. These must be ensured by the installation into the end device.

The print unit and parts of it (e.g. motor, printhead) can get hot during printing. Do not touch the printhead during operation. Cool down the print unit before changing material, removal or adjustment.

Never use highly inflammable consumables.

Carry out only the actions described in these operating instructions. Any work beyond this may only be performed by the manufacturer or upon agreement with the manufacturer.

Unauthorized interference with electronic modules or their software can cause malfunctions.

Other unauthorized work or modifications to the direct print module can endanger operational safety.

There are warning stickers on the direct print modules that draw your attention to dangers. Therefore the warning stickers are not to be removed as then you and others cannot be aware of dangers and may be injured.

**CAUTION!**

Two-pole fuse.

- ⇒ Before opening the housing cover, disconnect the printing system from the mains supply and wait for a moment until the power supply unit has discharged.

1.4 Decommissioning and Dismantling

**NOTICE!**

The decommissioning of printing system can only be carried out by trained staff.

**CAUTION!**

Danger of injury by imprudent handling when lifting or placing the printing system.

- ⇒ Do not underestimate the weight of the printing system (6 kg).
- ⇒ Do not lift the printing system at the hood.
- ⇒ Protect the printing system against uncontrolled movement.

2 Machine Overview

The continuous and intermittent operating direct print module with high resolution is designed for installation in horizontal and vertical packaging machines. Convincing is the availability of left and right versions. Thanks to the separate control unit the direct print module can be integrated almost in each packaging process without any problems.

Flexible labelling of packaging foil is effected either by means of Windows printer driver or by our proven design software Labelstar Office.

With eight vector fonts, six bitmap fonts and six proportional fonts the direct print module has a large selection at different font types. It can be printed inverse, in italic format or 90 degrees turned fonts.

The handling of our durable direct print modules is easy and comfortable. The parameter settings are made with the keys of the foil keyboard. At each time the graphic display shows the current status.

By a new-developed electronics a maximum print speed up to 400 mm/s can be achieved.

Time-saving printer update is possible by interface.

As default, the direct print module is equipped with a parallel, serial, USB and Ethernet interface. Additionally, the direct print module is equipped with an USB Host that permits the connection of an external USB keyboard and/or an USB memory stick. The direct print module automatically recognizes by which interface it is controlled.

Thanks to the large number of options the direct print module can be adapted to each task.

2.1 Figures

Connection side of print mechanics

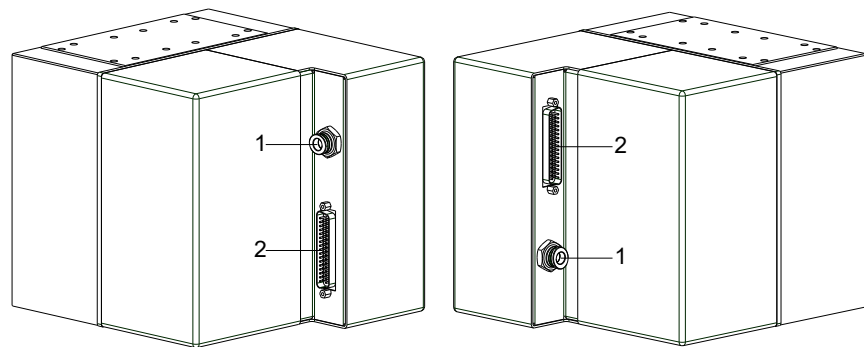

Figure 1

- 1 = Pneumatic connection
- 2 = Connecting cable (mechanics - control unit)

Front of the print unit

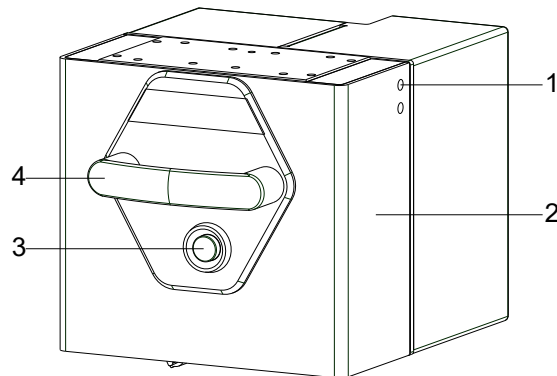

Figure 2

- 1 = Lift sensor, internal
- 2 = Cover
- 3 = Spring catch
- 4 = Handle

The cover (2) can be removed by the handle (4) with the spring catch (3) pressed down.



NOTICE!

No print job can be initiated when the cover is removed.

An internal cover sensor (1) checks the status of the cover (open/closed). This sensor does not satisfy the requirements of a standard-compliant safety switch (see chapter 1.3, on page 6).

Connector assignment of control unit

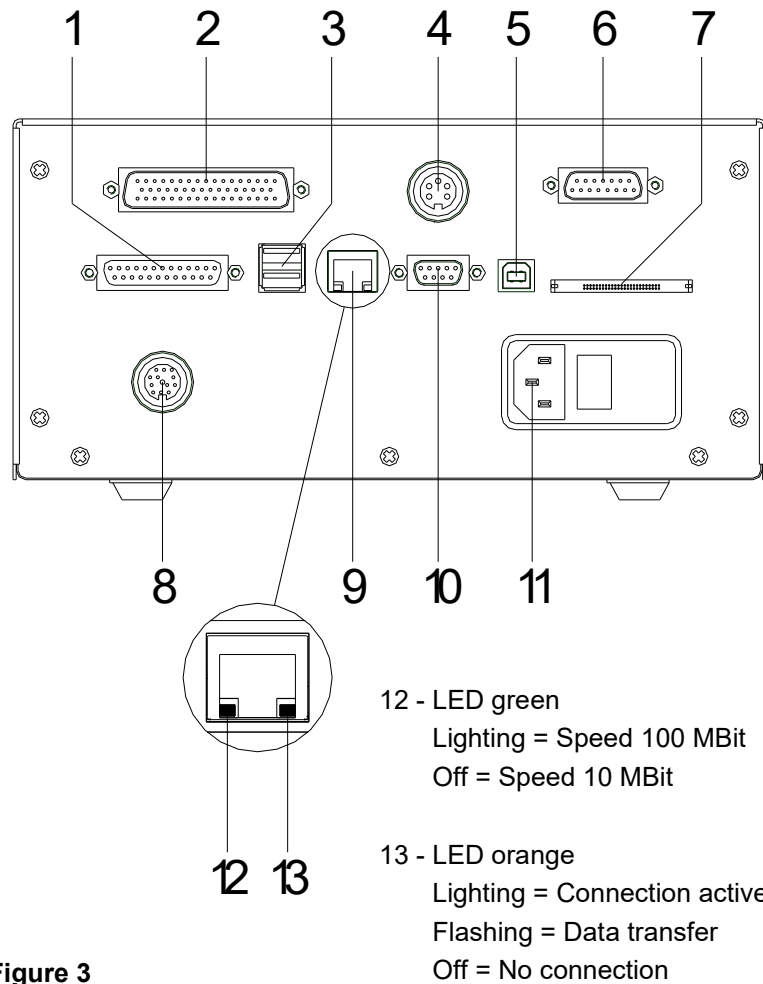

Figure 3

- 1 = Parallel interface
- 2 = Connecting cable (mechanics - control unit)
- 3 = USB host for USB keyboard and USB memory stick
- 4 = Encoder connection
- 5 = USB interface
- 6 = External inputs/outputs
- 7 = CF card slot
- 8 = Touch Panel connection
- 9 = Ethernet interface
- 10 = RS 232 interface
- 11 = Power supply with switch

2.2 Continuous Mode

Material Speed

Please note that the material has sufficient adhesion at the pressure transducer roll or encoder roll to permit the exact speed by the encoder.

It is only possible to print when respecting the operating conditions, i.e. the speed has to be observed.

Print Principle

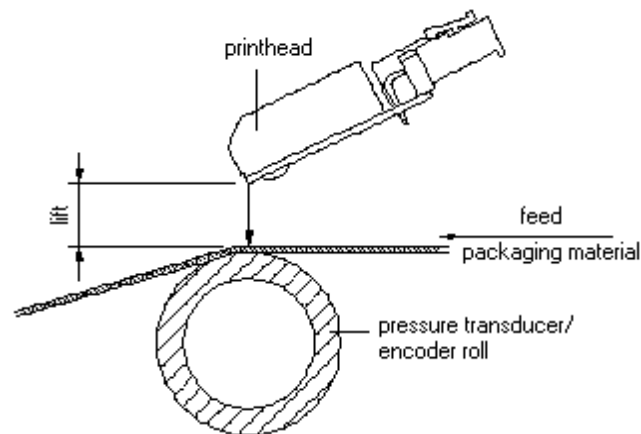

Figure 4

After starting a print order the printhead moves against the print medium. The feed of material is registered by the encoder and then evaluated. The printhead is in start position as long as the printing onto the moving material is finished and then it moves back to its home position.

Material Guiding

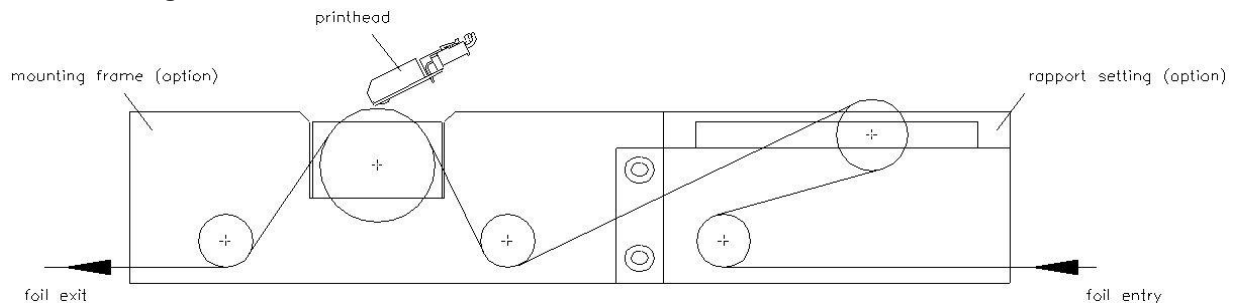

Figure 5



NOTICE!

In case the encoder is connected to the counter-pressure roll or the encoder roll you have to observe that the material has sufficient adhesion at the pressure roll or encoder roll to guarantee an exact speed by the encoder.

2.3 Intermittent Mode

Print Principle

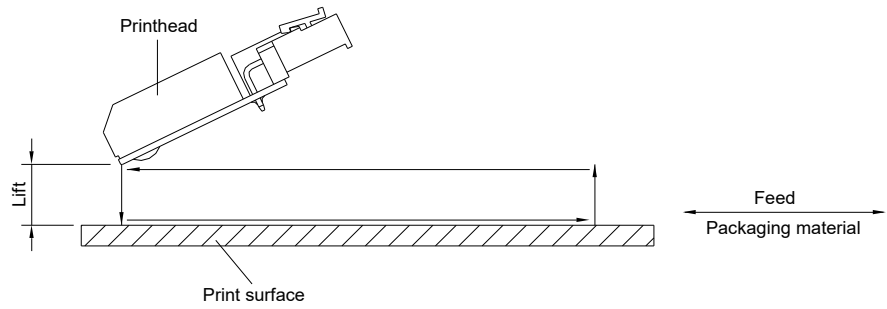

Figure 6

After starting a print order the printhead moves against the print medium. Afterwards the printing carriage moves corresponding to the set or transferred layout length linear over the material which is to be printed. After the print procedure the printhead again lifts up and the printing carriage moves again to the starting position.

Print Position

The direct print module has a print length of 40 mm maximum. The print start position is in a difference of approx. 40 mm to the side panel.

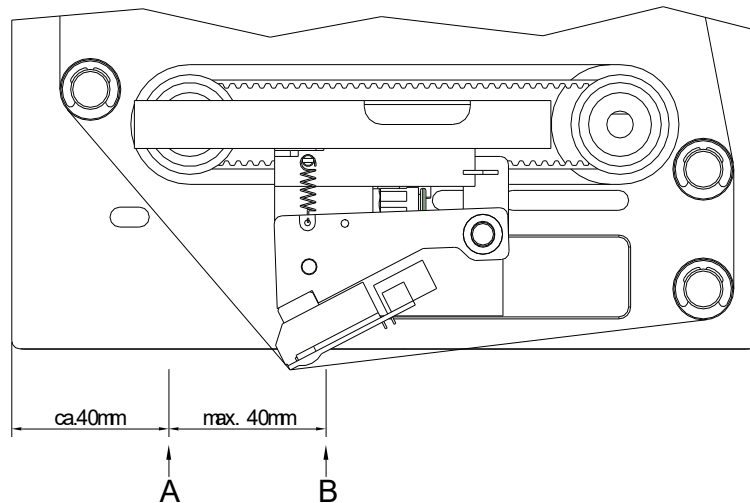

Figure 7

A: Start position

B: End position

3 Operating Conditions

Before initial operation and during operation these operating conditions have to be observed to guarantee save and interference-free service of our direct print modules.

Therefore please carefully read these operating conditions.

Shipment and storage of our direct print modules are **only** allowed in original packing.

Installation and initial operation of direct print modules is only allowed if operating conditions were **fulfilled**.

Initial operation, programming, operation, cleaning and service of our direct print modules are only recommended after careful study of our manuals.

Operation of direct print modules is only allowed by especially trained persons.



NOTICE!

Perform trainings regularly. Content of the training are chapter 3 (Operating Conditions), chapter 5.8 (Load Transfer Ribbon) and chapter 9 (Maintenance and Cleaning).

These indications are also valid for someone else's equipment supplied by us.

Only use original spare and exchange parts.

Please contact the manufacturer with respect to spare/wear parts.

Conditions for installation place

The installation place of direct print module should be even, free of vibration and currents of air are to be avoided.

The direct print modules have to be installed to ensure optimal operation and servicing.

Installation of power supply

The installation of the power supply to connect our direct print modules has to be effected according to the international rules and regulations, especially the recommendations of one of the three following commissions:

- International Electronic Commission (IEC)
- European Committee for Electro technical Standardisation (CENELEC)
- Verband Deutscher Elektrotechniker (VDE)

Our direct print modules are constructed according to VDE and have to be connected to a grounded conductor. The power supply has to be equipped with a grounded conductor to eliminate internal interfering voltage.

Technical data of power supply

Power line voltage and power line frequency: See type plate

Allowable tolerance of power line voltage:
+6 % ... -10 % of nominal value

Allowable tolerance of power line frequency:
+2 % ... -2 % of nominal value

Allowable distortion factor of power line voltage: ≤ 5 %

Anti-interference measures

In case your net is infected (e.g. by using thyristor controlled machines) anti-interference measures have to be taken. You can use one of the following possibilities:

- Provide separate power supply to our direct print modules.
- In case of problems please connect capacity-decoupled isolation transformer or similar interference suppressor in front of our direct print modules.

Connecting lines to external machines

All connecting lines have to be guided in shielded lines. Shielding has to be connected on both sides to the corner shell.

It is not allowed to guide lines parallel to power lines. If a parallel guiding cannot be avoided a distance of at least 0.5 m has to be observed.

Temperature of lines between: -15 ... +80 °C.

It is only allowed to connect devices which fulfil the request 'Safety Extra Low Voltage' (SELV). These are generally devices which are checked corresponding to EN 62368-1.

Installation of data lines

The data cables must be completely protected and provide with metal or metallised connector housings. Shielded cables and connectors are necessary, in order to avoid radiant emittance and receipt of electrical disturbances.

Allowable lines

Shielded line:

4 x 2 x 0,14 mm² (4 x 2 x AWG 26)
6 x 2 x 0,14 mm² (6 x 2 x AWG 26)
12 x 2 x 0,14 mm² (12 x 2 x AWG 26)

Sending and receiving lines have to be twisted in pairs.

Maximum line length:

with interface V 24 (RS-232C) - 3 m (with shielding)
with parallel interface - 3 m (with shielding)
USB - 3 m
Ethernet - 100 m

Air convection To avoid inadmissible heating, free air convection has to be ensured.

Limit values

Protection according IP: 20

Ambient temperature °C (operation): Min. +5 Max. +40

Ambient temperature °C (transport, storage): Min. -25 Max. +60

Relative air humidity % (operation): Max. 80

Relative air humidity % (transport, storage): Max. 80
(bedewing of printers not allowed)

Guarantee

We do not take any responsibility for damage caused by:

- Ignoring our operating conditions and operating manual.
- Incorrect electric installation of environment.
- Building alterations of our printers.
- Incorrect programming and operation.
- Not performed data protection.
- Using of not original spare parts and accessories.
- Natural wear and tear.

When (re)installing or programming our direct print modules please control the new settings by test running and test printing. Herewith you avoid faulty results, reports and evaluation.

Only specially trained staff is allowed to operate the direct print modules.

Control the correct handling of our products and repeat training.

We do not guarantee that all features described in this manual exist in all models. Caused by our efforts to continue further development and improvement, technical data might change without notice.

By further developments or regulations of the country illustrations and examples shown in the manual can be different from the delivered model.

Please pay attention to the information about admissible print media and the notes to the printer maintenance, in order to avoid damages or premature wear.

We endeavoured to write this manual in an understandable form to give you as much information as possible. If you have any queries or if you discover errors, please inform us to give us the possibility to correct and improve our manual.

4 Technical Data

	Flexicode 53
Print resolution	300 dpi
Print speed	50 ... 400 mm/s
Back speed	max. 600 mm/s (intermittent mode only)
Print width	53 mm
Print length	continuous mode: max. 3000 mm intermittent mode: max. 40 mm
Frame passage width	customized
Printhead	Corner Type
Acoustic Emission	
Average sound power level	69 dB(A) - Measuring distance 1 m
Transfer Ribbon	
Ink	outside / inside
Roll diameter	max. 82 mm
Core diameter	25,4 mm / 1"
Length	max. 450 m
Width	max. 55 mm
Dimensions (width x height x depth)	
Print mechanics without mounting frame with mounting frame	190 mm x 180 mm x 208 mm depends on passage width
Control unit	242 mm x 117 mm x 220 mm (connecting cable set to mechanics 2.5 m)
Weight	
Print mechanics	6,0 kg
Electronics with cable	3.7 kg
Electronics	
Processor	High Speed 32 Bit
RAM	16 MB
Slot	Compact Flash card type I
Battery cache	for Real-Time clock (storage of data with shut-down)
Warning signal	acoustic signal when error
Interfaces	
Serial	RS-232C (up to 115.200 Baud)
Parallel	SPP
USB	2.0 High Speed Slave
Ethernet	10/100 Base T, LPD, RawIP-Printing, DHCP, HTTP, FTP
2 x USB Master	connection for external USB keyboard and memory stick
Connection Values	
Pneumatic connection	6 bar dry and free of oil
Air consumption typical* * hub 1,5 mm 150 cycle/min 6 bar operating pressure	150 ml/min
Nominal voltage	200-240 V AC, 3 A, 50/60 Hz 100-120 V AC, 3 A, 50/60 Hz (option)
Fuse values	2x T4A 250 V
Operation Data	
Temperature	5 ... 40 °C
Humidity	max. 80 % (non-condensing)

	Flexicode 53
Operation Panel	
Keys	test print, function menu, quantity, CF Card, feed, enter, 4 x cursor
LCD display	graphic display 132 x 64 pixel
Settings	
	date, time, shift times 20 language settings (others on demand) print and device parameters, interfaces, password protection
Monitoring	
Stop printing if	end of ribbon / end of layout
Status report	extensive status print with information about settings e.g. print length counter, runtime counter, photocell interface and network parameters printout of all internal fonts and all supported bar codes
Fonts	
Font types	6 Bitmap fonts, 8 Vector fonts/TrueType fonts, 6 proportional fonts other fonts on demand
Character sets	Windows 1250 up to 1257, DOS 437, 850, 852, 857 all West and East European Latin, Cyrillic, Greek and Arabic (option) characters are supported other character sets on demand
Bitmap fonts	size in width and height 0,8 ... 5,6 zoom 2 ... 9, orientation 0°, 90°, 180°, 270°
Vector fonts/ TrueType fonts	size in width and height 1 ... 99 mm variable zoom orientation 0°, 90°, 180°, 270°
Font attributes	depending on character font - bold, Italic, inverse, vertical
Font width	variable
Bar Codes	
1D bar codes	2/5 Industrial, Codabar, Code 128, Code 128A, Code 128B, Code 2/5 interleaved, Code 39, Code 39 extended, Code 93, EAN 13, EAN 8, EAN Add-on, GS1-128, Identcode, ITF 14, Leitcode, Pharmacode, PLANET (Postal Alpha Numeric Encoding Technique), PostNet, PZN 7, PZN 8, UPC-A, UPC-E, USPS Intelligent Mail
2D bar codes	Aztec Code, CODABLOCK F, DataMatrix, GS1 DataMatrix, MAXICODE, PDF 417, QR Code
Composite bar codes	GS1 DataBar Expanded, GS1 DataBar Limited, GS1 DataBar Omnidirectional, GS1 DataBar Stacked, GS1 DataBar Stacked Omnidirectional, GS1 DataBar Truncated
	all bar codes are variable in height, module width and ratio. orientation 0°, 90°, 180°, 270°. Optionally with check digit and human readable line.
Software	
Configuration	ConfigTool
Process control	Loftware
Design software	Labelstar Office Lite, Labelstar Office
Windows printer driver	Windows 8.1® - Windows 10® 32/64 Bit, Windows 11® Windows Server 2016® - Windows Server 2022®

Technical details are subject to change.

4.1 Control Inputs and Outputs

By means of a maximum of 16 control inputs and outputs which, in the following, are also referred to as ports, different functions of the printer system can be triggered and operating states can be displayed.

The ports are provided by means of a D-Sub bushing (26pin HD) at the rear panel of the printer system and are galvanically isolated from protective earth (PE) by means of an optocoupler semi-conductor route.

Each port can be configured as input and as output. This function however, is predefined in the printer software and cannot be changed by the user.

The following parameters can be changed and set by using the menu: debounce times and high or low active.

Printer, internal circuitry

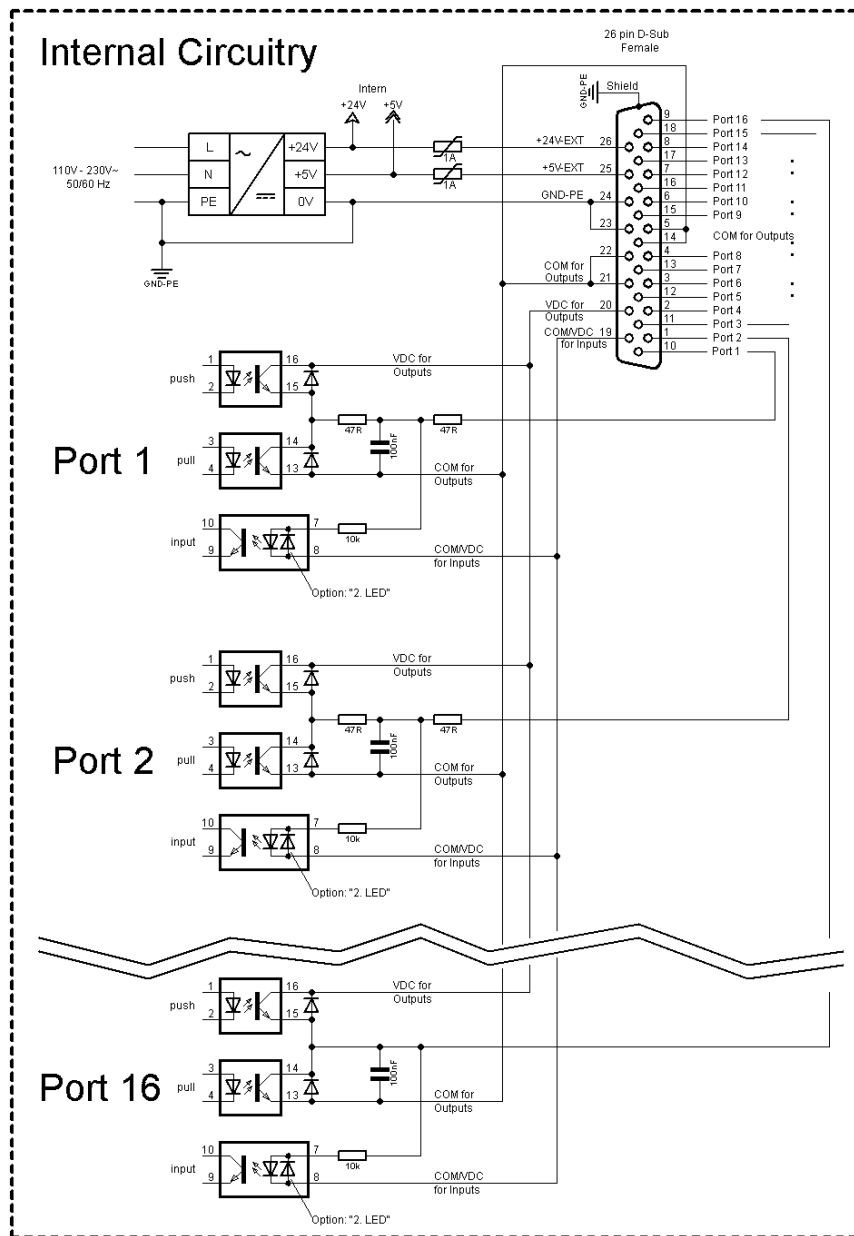

Figure 8

Configuration of D-Sub socket

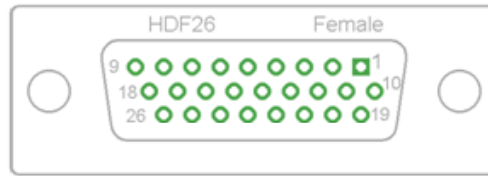

Figure 9

Cable identification

Number	Color
1	white
2	brown
3	green
4	yellow
5	grey
6	pink
7	blue
8	red
9	black
10	violet
11	grey-pink
12	red-blue
13	white-green
14	brown-greed
15	white-yellow
16	yellow-brown
17	white-grey
18	grey-brown
19	white-pink
20	pink-brown
21	white-blue
22	brown-blue
23	white-red
24	brown-red
25	white-black
26	brown-black

Port 1 to Port 16 = Assignment for I/O Profile *Std_Direct*

Port	Pin	Description / Function
1 (Input)	10	Print start
2 (Input)	1	Return printing carriage (operating mode Retracting 'external' only)
3 (Input)	11	Counter reset
4 (Input)	2	Release signal
5 (Input)	12	Error reset
6 (Input)	3	Delete all print orders
7 (Input)	13	No function
8 (Input)	4	No function
9 (Output)	15	Error
10 (Output)	6	Print order active
11 (Output)	16	No function
12 (Output)	7	Printing
13 (Output)	17	Ready
14 (Output)	8	Transfer ribbon error
15 (Output)	18	Return printing carriage
16 (Output)	9	Transfer ribbon prior warning
COM/VDC for Inputs	19	Common reference potential of all control inputs. 'COM/VDC for Inputs' is usually connected with the (-) terminal of the control voltage and the control inputs are switched to active (+). By means of the option '2nd LED', 'COM/VDC for Inputs' can optionally be connected with the (+) terminal of the control voltage. Then, the control inputs are switched to active (-).
VDC for Outputs	20	Common supply connection of all control outputs. 'VDC for Outputs' must be connected with the (+) terminal of the control voltage. Never leave 'VDC for Outputs' open even if no output is used.
COM for Outputs	5,14 21,22	Common reference potential of all control outputs. 'COM for Outputs' must be connected with the (-) terminal of the control voltage. Never leave 'COM for Outputs' open even if no output is used.
GND-PE	23,24	'GND-PE' is the reference potential of the '+5 VDC EXT' and '+24 VDC EXT' voltages provided by the printer system. 'GND-PE' is printer internally connected with protective earth (PE).
+ 5 VDC EXT	25	5 Volt DC output for external use. Max. 1 A. This voltage is provided from direct print module and can be used e.g. as control voltage. Never apply any external voltage to this output.
+ 24 VDC EXT	26	24 Volt DC output for external use. Max. 1 A. This voltage is provided from direct print module and can be used e.g. as control voltage. Never apply any external voltage to this output.

Port 1 to Port 16 = Assignment for I/O Profile *StdFileSelDirect*

Port	Pin	Description / Function
1 (Input)	10	Print start
2 (Input)	1	Error reset
3 (Input)	11	Number of the file to load Bit 0 (Input)
4 (Input)	2	Number of the file to load Bit 1 (Input)
5 (Input)	12	Number of the file to load Bit 2 (Input)
6 (Input)	3	Number of the file to load Bit 3 (Input)
7 (Input)	13	Number of the file to load Bit 4 (Input)
8 (Input)	4	Number of the file to load Bit 5 (Input)
9 (Output)	15	Error
10 (Output)	6	No function
11 (Output)	16	No function
12 (Output)	7	No function
13 (Output)	17	Ready
14 (Output)	8	No function
15 (Output)	18	Return printing carriage
16 (Output)	9	Transfer ribbon prior warning

* The files must be saved onto the CF card in the user directory.

The files must start with 1 or 2 digits (1_Etikett.prn, 02_Etikett.prn).

The files can be saved with a file extension.

In the printer status 'ready', 'waiting' or 'stop', a new file can be loaded. The printer order will be started after charging and an already existing printer order will be deleted.

The input signal 000000 does not charge a file and does not delete an already existing print order.

Port 1 to Port 16 = Assignment for I/O Profile *SP_Direct0*

Port	Pin	Description / Function
1 (Input)	10	Print start
2 (Input)	1	No function
3 (Input)	11	Counter reset
4 (Input)	2	No function
5 (Input)	12	Error reset
6 (Input)	3	No function
7 (Input)	13	No function
8 (Input)	4	No function
9 (Output)	15	Error
10 (Output)	6	Active print order
11 (Output)	16	No function
12 (Output)	7	Printing
13 (Output)	17	Ready
14 (Output)	8	No function
15 (Output)	18	Return
16 (Output)	9	Transfer ribbon prior warning

Port 1 to Port 16 = Assignment for I/O Profile *Old_Direct0*

Port	Pin	Description / Function
1 (Input)	10	Print start
2 (Input)	1	Error reset
3 (Input)	11	Counter reset
4 (Input)	2	No function
5 (Input)	12	No function
6 (Input)	3	No function
7 (Input)	13	No function
8 (Input)	4	No function
9 (Output)	15	Error
10 (Output)	6	Active print order
11 (Output)	16	Generation
12 (Output)	7	Printing
13 (Output)	17	Print-Ready
14 (Output)	8	Printhead up
15 (Output)	18	Return
16 (Output)	9	Transfer ribbon prior warning

Port 1 to Port 16 = Assignment for I/O Profile *Old_Direct1*

Port	Pin	Description / Function
1 (Input)	10	Print start
2 (Input)	1	Error reset
3 (Input)	11	Counter reset
4 (Input)	2	No function
5 (Input)	12	No function
6 (Input)	3	No function
7 (Input)	13	No function
8 (Input)	4	No function
9 (Output)	15	Error
10 (Output)	6	Active print order
11 (Output)	16	Generation
12 (Output)	7	Printing or return
13 (Output)	17	Print-Ready
14 (Output)	8	Printhead up
15 (Output)	18	Return
16 (Output)	9	Transfer ribbon prior warning

Port 1 to Port 16 = Assignment for I/O Profile *Old_Direct2*

Port	Pin	Description / Function
1 (Input)	10	Print start
2 (Input)	1	Error reset
3 (Input)	11	Counter reset
4 (Input)	2	Release signal
5 (Input)	12	No function
6 (Input)	3	No function
7 (Input)	13	No function
8 (Input)	4	No function
9 (Output)	15	Error
10 (Output)	6	Active print order
11 (Output)	16	Generation
12 (Output)	7	Printing or return
13 (Output)	17	Print-Ready
14 (Output)	8	Printhead up
15 (Output)	18	Return
16 (Output)	9	Transfer ribbon prior warning

Technical data

Plug Connector	
Type	D-Sub connector High Density 26-pin. / connector
Manufacturer	W+P-Products
Reference number	110-26-2-1-20
Output Voltages (connected with GND-PE)	
+ 24 V / 1 A	Fuse: Polyswitch / 30 V / 1 A
+ 5 V / 1 A	Fuse: Polyswitch / 30 V / 1 A
Port 1 - 15	
Input	
Voltage	5 VDC ... 24 VDC
Impedance	47Ω + (100nF 10 kΩ)
Output	
Voltage	5 VDC ... 24 VDC
Impedance	47Ω + (100nF 10 kΩ 47Ω)
Current max.	High +15 mA Low -15 mA
Port 16	
Input	
Voltage	5 VDC ... 24 VDC
Impedance	100nF 10 kΩ
Output	
Voltage	5 VDC ... 24 VDC
Impedance	100nF 10 kΩ
Current max.	High +500 mA (Darlington BCP56-16) Low - 500 mA (Darlington BCP56-16)
Optocoupler	
Output	TCMT4106, CTR 100 % - 300 %, Vishay or TLP281-4(GB), CTR 100 % - 600 %, Toshiba
Input	TCMT4106, CTR 100 % - 300 %, Vishay or TLP281-4(GB), CTR 100 % - 600 %, Toshiba
Input Option 2nd LED	TCMT4600, CTR 80 % - 300 %, Vishay or TLP280-4, CTR 33 % - 300 %, Toshiba

Example 1

Device connection to a machine with S7-300 SPS.

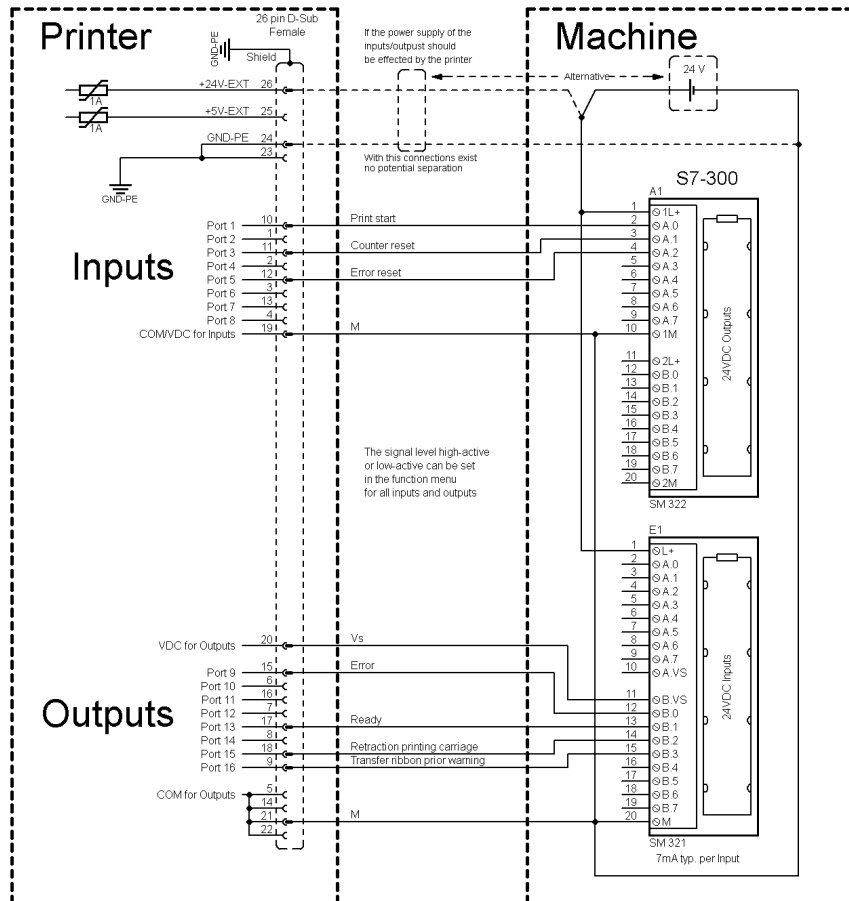

Figure 10

Example 2

Device connection to a operating panel.

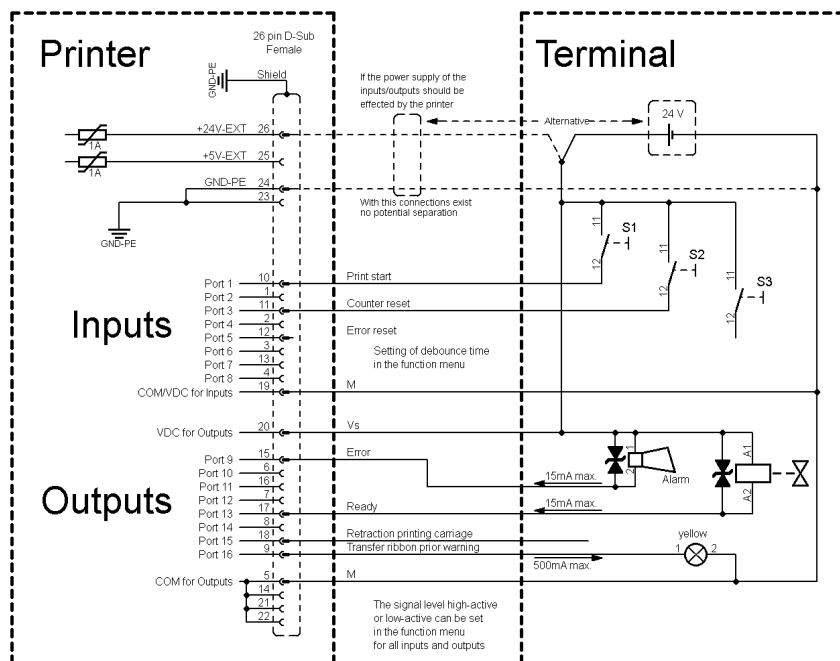

Figure 11

Example 3

Device connection version if 'Option: 2. LED'.

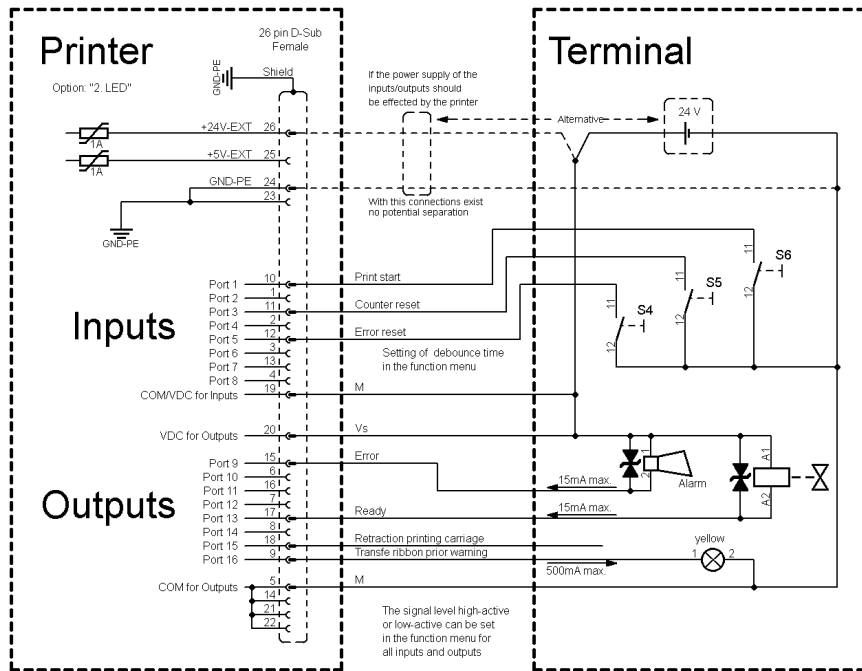

Figure 12

Precautions

When connecting a reed contact with a control input, the contact must have a switching capacity of min. 1 A in order to prevent the contact from sticking due to the inrush current. As an alternative, a suitable resistor can be connected in series.

If one of the printer's internal voltages '+5 VDC EXT' or '+24 VDC EXT' is used, an external fuse e.g. 0.5 AF, should be additionally installed to protect the printer electronics.

In the event of an inductive load, an antiparallel connected diode, for instance, must be used to discharge the induction energy.

In order to minimise the influence of leakage currents at control outputs, a resistor must, depending on what is connected, be installed in parallel with the load.

In order to avoid any damages to the printing system, the max. output currents must not be exceeded or outputs shorted.

4.2 Pin Assignment of Encoder Socket *

5-pin connecting bushing, contacts according to DIN 45322

connector socket
encoder

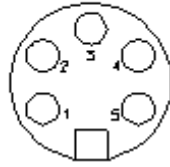

PIN1 = 5 VDC

PIN2 = Encoder signal (channel A)

PIN3 = Encoder signal (channel B)

PIN4 = GND

Electrical data of encoder

Operating voltage:	5 VDC
Output signal:	TTL level
Resolution:	Can be set at the print module

Connect the encoder

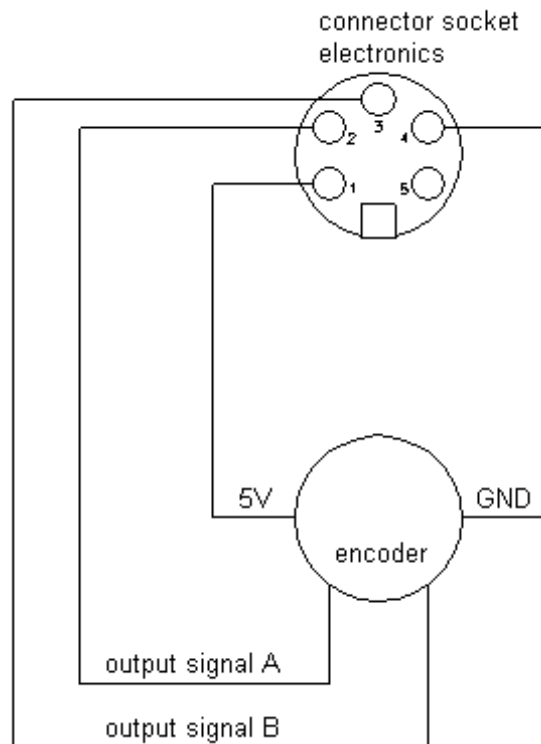

* only for continuous mode

5 Installation and Initial Operation

Unpack/pack the direct print module



CAUTION!

Danger of injury by imprudent handling when lifting or placing the printing system.

- ⇒ Do not underestimate the weight of the printing system (6 kg).
- ⇒ Do not lift the printing system at the hood.
- ⇒ Protect the printing system against uncontrolled movement.

- ⇒ Lift the direct print module out of the box.
- ⇒ Check the direct print module for transport damages.
- ⇒ Remove the foam transportation safeguards near the printhead.
- ⇒ Check delivery for completeness.

Scope of delivery

- Print mechanics.
- Control unit.
- Power cable.
- Connecting cable.
- Mini controller.
- Manometer.
- Pneumatic tube.
- Push-on connector.
- I/O accessories (female connectors for I/O I/O 24 cable).
- 1 transfer ribbon roll.
- Empty core, mounted on transfer ribbon rewinder.
- Cleaning foil for printhead.
- Product Safety Guide.



NOTICE!

Retain the original packaging for subsequent transport.

5.1 Install the Print Mechanics at Machines

Installation with mounting frame



NOTICE!

With the open printing unit (due to construction) the requirements of EN 62368-1 regarding fire protection casing are not fulfilled. These must be ensured by the installation into the end device.

At the bottom of the print mechanics are two M8 threads that can be used to fasten the print mechanics.

Please observe the following conditions:

- The maximum thread engagement of the M8 threads is 10 mm.
- The print mechanics has to be installed with a distance from printhead to brake stator of 1 ... 2.5 mm (see illustration).



NOTICE!

A distance of 2 mm is recommended.

- The best print results can be received if the silicon of printing roll consists of a hardness of approx. 60 ± 5 Shore A (average value of roughness $R_a \geq 3,2$ mm).
- The print surface has to be installed parallel to the linear movement of print unit and the focal line of printhead. Discrepancies to the focal line and cavities in the print surface can lead to an inferior print quality at these positions.

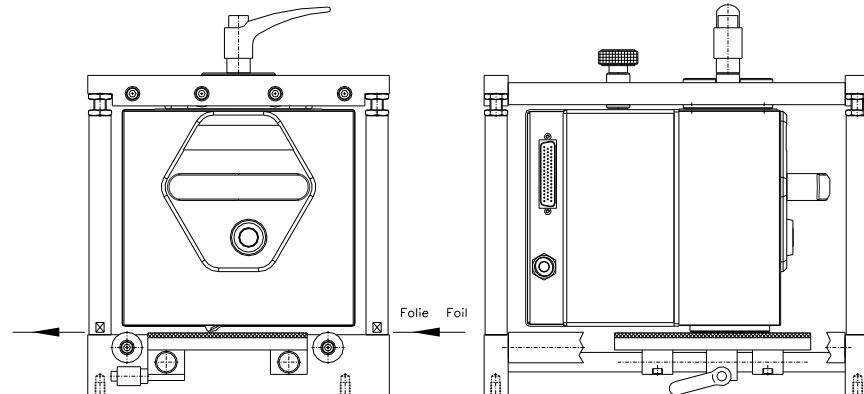
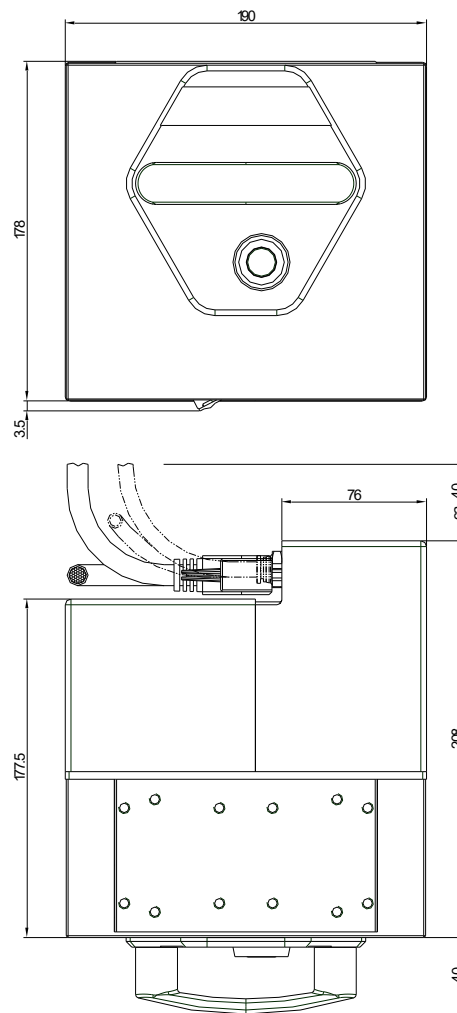

Figure 13

Installation without mounting frame

In case the machine is used without mounting frame, then the print module is fixed from the top with four M6 screws.

The maximum thread engagement of the M6 threads is 6 mm. (position of printhead see illustration)

Required space for outgoing cable**Figure 14****NOTICE!**

The well-thought-out housing concept provides multiple possibilities for the cable outgoing. With small space requirements the cables can be directed upwards, downwards and to the side.

5.2 Connect the Pneumatic Power Supply

The pneumatic power supply for the printhead mechanics has to be made available a minimum continuous pressure of 4 ... 6 bars in front of the pressure regulator. The maximum pressure in front of the pressure regulator is 7 bars and 4 bars after the pressure regulator.



NOTICE!

A pneumatic power supply of 4 bars is recommended.

The compressed-air has to be dry and oil free.

The supplied pressure regulator with manometer is to connect with a plastic tube \varnothing 8 mm via a plugging bolting to the pneumatic power supply. It is necessary to make a connection between the pressure regulator and the print mechanics via a plastic tube \varnothing 8 mm.

Please observe the following notes:

- Position the pressure regulator as near as possible to the print mechanics.
- The pressure regulator is only to operate in the direction that is indicated on its underside. The direction shows the way of the streaming air.
- It is not allowed to bend the plastic tubes.
- Shortening of the plastic tubes has to be made with a clean right-angled cut without squashing the tube. If necessary use special tools (available in pneumatic requirements).
- Please observe a possible short length of the 8 mm plastic tubes.

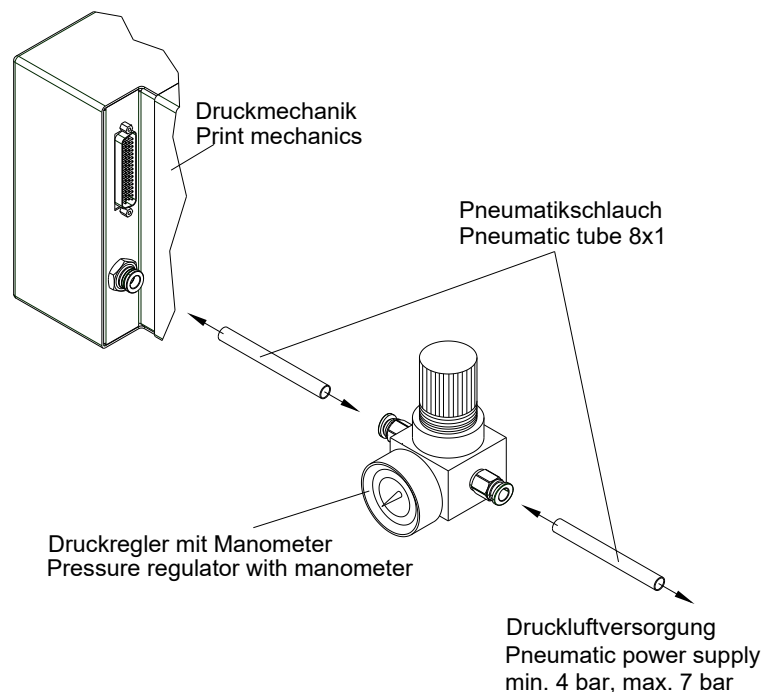
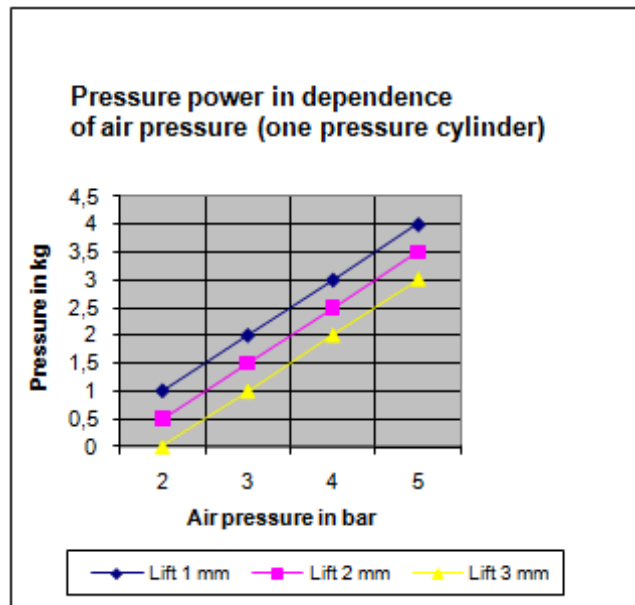

Figure 15

5.3 Adjust the Pressure Power



The pressure power of the printhead can be set with the pressure regulator. The values are indicated in the following table:



NOTICE!

If the pressure power is too low then the printhead has no more contact to the counter-pressure plate. Due to the missing heat dissipation while printing the printhead is damaged. An error message appears in case of too less pressure. This error message serves to prevent overheating the printhead and is not suitable as pressure quality monitoring. The print quality is also reduced with too low pressure.

'Lift' indicates the distance between the printhead and counter-pressure plate in idle mode of device.

Recommended pressure power: 40 N

Max. pressure power: 45 N

As the mechanical wear and tear of the printhead increases with the pressure power, the pressure power should be as low as possible.

5.4 Connect the Direct Print Module

Connect to the power supply

The direct print module is prepared according to standard for a mains voltage of 200-240 V AC, 50/60 Hz. Optionally a mains voltage can be used by 100-120 V AC, 50/60 Hz. The set mains voltage is mentioned on the type plate.



CAUTION!

The direct print module can be damaged by undefined switch-on currents.

⇒ Set the power switch to '0' before plugging in the direct print module.

⇒ Insert the power cable into the power connection socket.

⇒ Insert the plug of power cable into a grounded electrical outlet.

Connect to a computer or to a computer network



NOTICE!

Insufficient or missing grounding can cause faults during operation.

Ensure that all computers and connection cables connected to the direct print module are grounded.

⇒ Connect the direct print module to a computer or network with a suitable cable.

5.5 Before Initial Operation

- Mount the print mechanics.
- Connect all cables between the print mechanics and control unit.
- Protect the cables against unintentional unscrewing.
- Connect the compressed air line.
- Connect the control unit and PC by printer interface.
- Connect the control unit and packaging machine by inputs and outputs.
- Connect the power cable of control unit.

5.6 Print Control

As the direct print module is always in control mode, print orders can only be transmitted but not started via the existing interfaces (serial, parallel, USB or Ethernet). The print is started by a start signal to the 'print start-control input'. So that the control unit detects when the start signal can be set, it is possible and mostly necessary to track the print status via the control outputs.

5.7 Initial Operation

- ⇒ After all connections are completed, switch on the control unit. The main menu appears which shows the model type, current date and time.
- ⇒ Insert the transfer ribbon (see chapter 5.8, page 38).

5.8 Load Transfer Ribbon



NOTICE!

As for the electrostatic unloading the thin coating of the thermal printhead or other electronic parts can be damaged, the transfer ribbon should be antistatic.

The use of wrong materials can lead to printer malfunctions and the guarantee can expire.

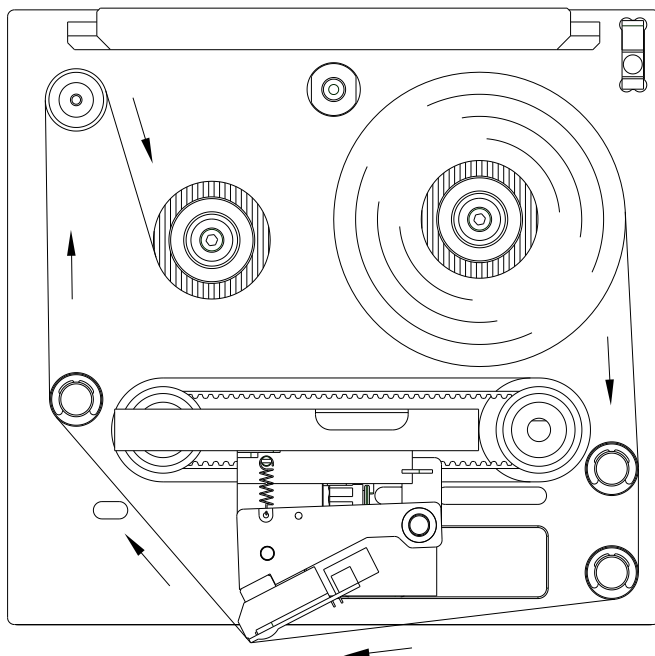

1. Remove the cover by the handle with the spring catch pressed down (3, Figure 2).
2. Load a new ribbon roll as far as it will go onto the unwinding roll.
3. Load an empty roll as far as it will go onto the rewinding unit.
4. Insert the transfer ribbon according to the illustration.
5. Fix the ribbon with an adhesive tape at the empty roll and tighten it by some turns of the core.
6. Reinstall the protection cover.

Figure 16



NOTICE!

Before a new transfer ribbon roll is loaded, the printhead must be cleaned using printhead and roller cleaner (97.20.002). For detailed information, please see page 91.

The handling instructions for the use of Isopropanol (IPA) must be observed. In the case of skin or eye contact, immediately wash off the fluid thoroughly with running water. If the irritation persists, consult a doctor. Ensure good ventilation.



CAUTION!

Impact of electrostatic material on people!

- ⇒ Use antistatic transfer ribbon because electrostatic discharge can occur when removing.

5.9 Increase the Clamping Force for Ribbon Roll



NOTICE!

We recommend the use of high-quality transfer ribbon with a cardboard core. A sample ribbon roll is included in the scope of delivery. The clamping force of transfer ribbon roll placed on the rewinding/unwinding unit is designed for this quality.

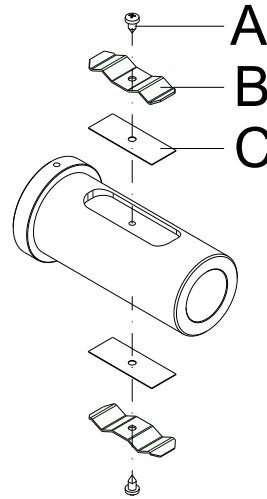

Figure 17

If other transfer ribbons are used, it can occur that the clamping force of the spring plates (B) is not sufficient, in order to position the rolls surely and to protect it against rotating.

When using transfer ribbons with plastic cores a safe positioning of the roles cannot be ensured.



CAUTION!

Slippage of transfer ribbon roll placed on the rewinding/unwind unit or the empty cardboard core leads to malfunctions.





















⇒ When using transfer ribbon rolls with plastic cores the groove must be shimmed.

Increase the clamping force

- Remove the screws (A) and spring plates (B).
- Insert the shim (C) into the groove. Available from us (52.57.110).
- Fasten again the spring plates (B) and shims (C) with screws (A).
- Insert the transfer ribbon roll and empty cardboard core on the rewinding/unwinding unit.
Check firm position!

6 Operation Panel

6.1 Keyboard (Standard)

Key	Function
	Back to the main menu. Start a test print. Delete a stopped print order.
	Change to the function menu. In function menu: one menu item back.
	Change to the quantity (number of pieces) menu. Press the keys  and  to select the number of layouts that should be printed.
	Change to the menu of the CF card.
	In main menu: feed of one layout. In function menu: skip to the next menu item. In dispenser mode: release of start signal.
	Confirm settings and modifications. Stop and continue current print orders. Delete a stopped print order with the key  . No further layout of the print order is printed.
	Return to the previous input field. Press the keys  and  to change the values.
	Skip to the next input field. Press the keys  and  to change the values.
	In function menu: increase the figure at the cursor position. In main menu: upwards movement of the printhead.
	In function menu: decrease the figure at the cursor position. In main menu: downwards movement of the printhead.
	Delete the complete input.
	Confirm settings in the function menu. After confirmation of settings, return to the main menu.
	Not yet in use.
	Not yet in use.

6.2 Keyboard (Text Entry/User Guiding)

The control unit of the print module is equipped with an alphanumeric character block which allows the user to enter parameters and customised variables without the connection of an external keyboard. Each key contains letters and similar to the use of a mobile phone (like sms) a direct and time-saving input is possible.

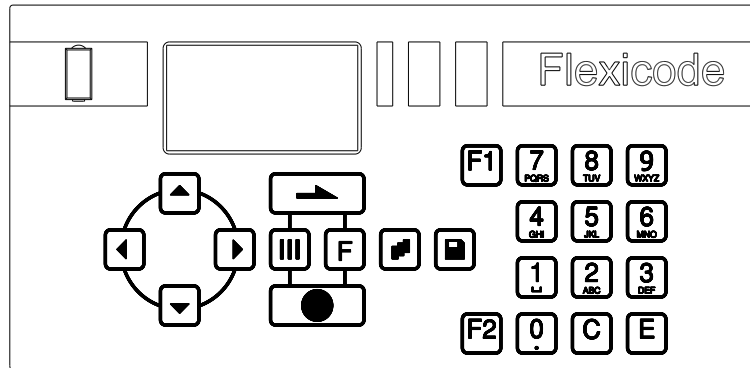

The mode is displayed in the first line at the right position so the user can control in which input mode is selected.

As the input is almost done with characters from one mode, the characters are divided in different groups. Following input modes are available:

Symbol	Modus
0	Standard, starting with figures
M	Starting with capital letters
m	Starting with small letters
A	Input Alt
a	Input Alt, is switched off after one character

Mode 0

This mode is displayed as default. At first the figure which corresponds to the key is displayed, then all capital and afterwards the small letters.

Mode M

At first all capital, then the small letters and at last the corresponding figure.

Mode m















At first all small letters, then the figure and at last the capital letters.

Mode A

This mode can be used for the creation of special characters. The desired character can be displayed by the assigned number by entering the ANSI code. Please note that the ANSI code has to consist of three digits, i.e. you have possible to enter a zero first.

Mode a

Same as mode A. After input of the selected ANSI code the machine, however, changes back to the previously selected input mode.

Key	Function
	Back to the main menu. Start a test print. Delete a stopped print order.
	Not yet in use.
	Delete the character at the cursor position. If the cursor is between the last character then the last character is deleted. The characters are deleted only if they were entered via the character block.
	Select the entry mode.
	Confirm the entry and change to the main menu.
	Confirm and/or finish the entry.
	Cursor moves one position to the left.
	Cursor moves one position to the right.
	Customized variables (user guiding): Change between the individual entries.
	Customized variables (user guiding): Change between the individual entries.
	Delete the complete input. The input is deleted only if before entered by using the number block.
	Confirm the settings in the function menu. After confirmation of the settings, return to the main menu.
	Not yet in use.
	Not yet in use.

7 Function Menu

7.1 Menu Structure (Continuous Mode)

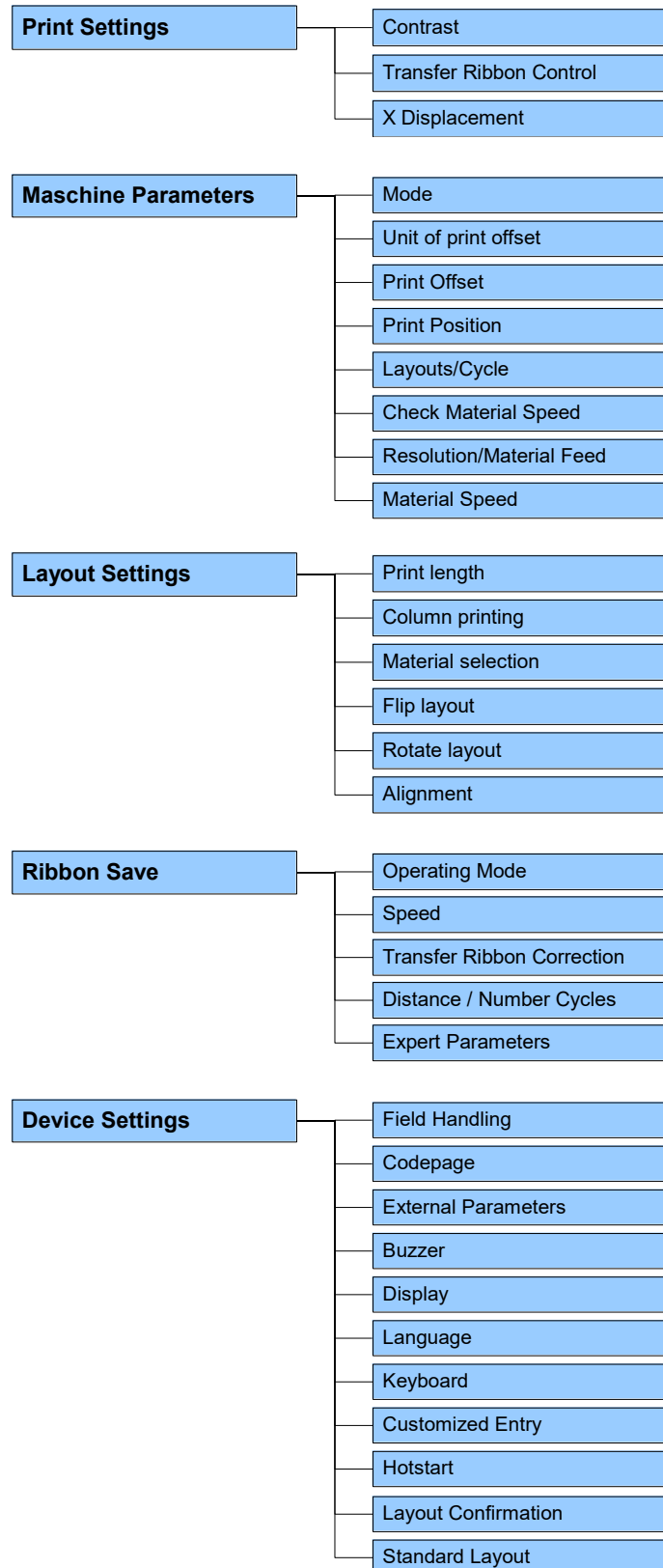

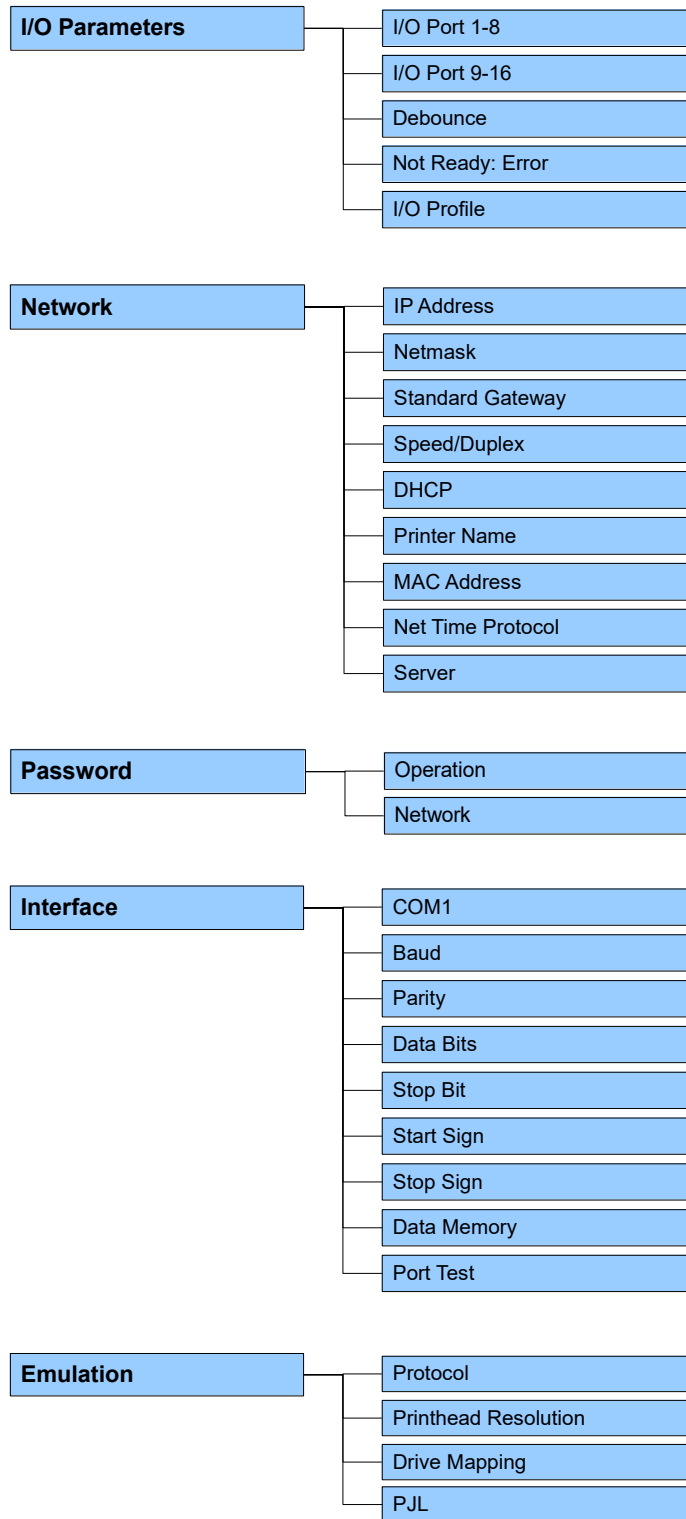

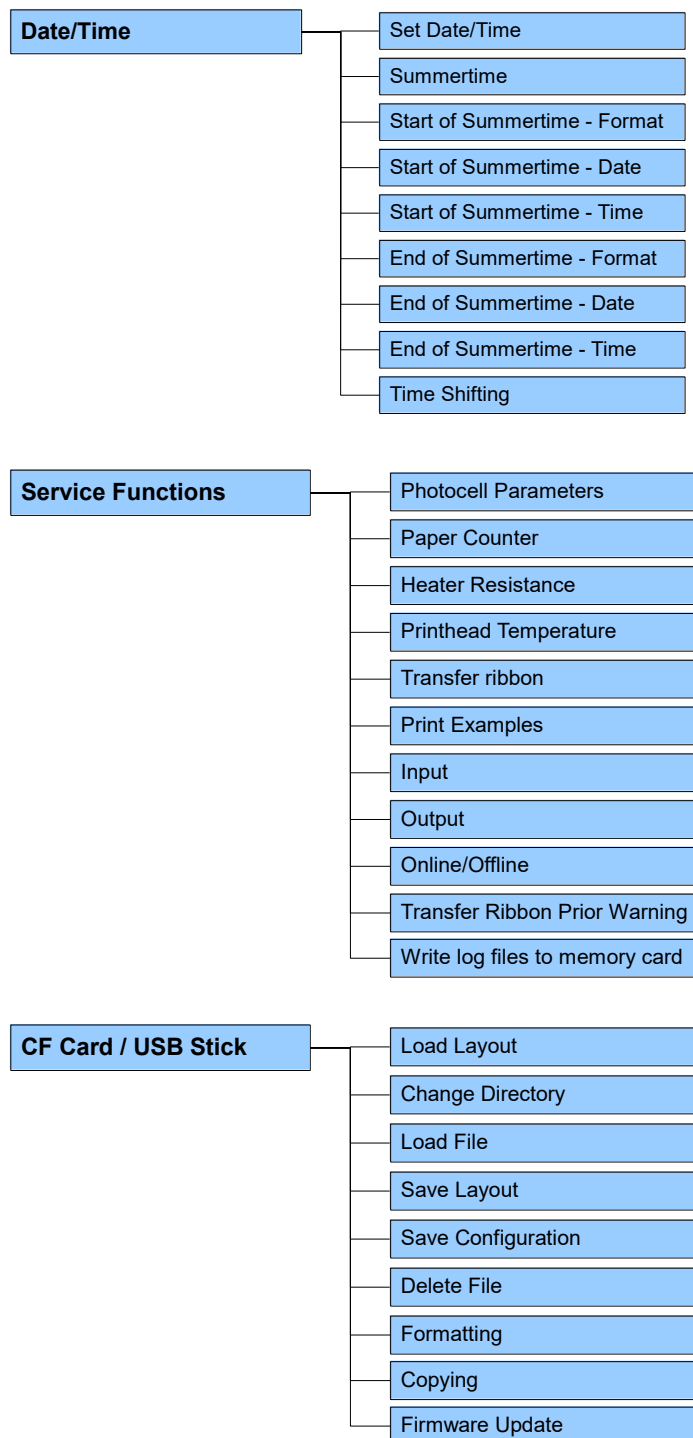

7.2 Menu Structure (Intermittent Mode)

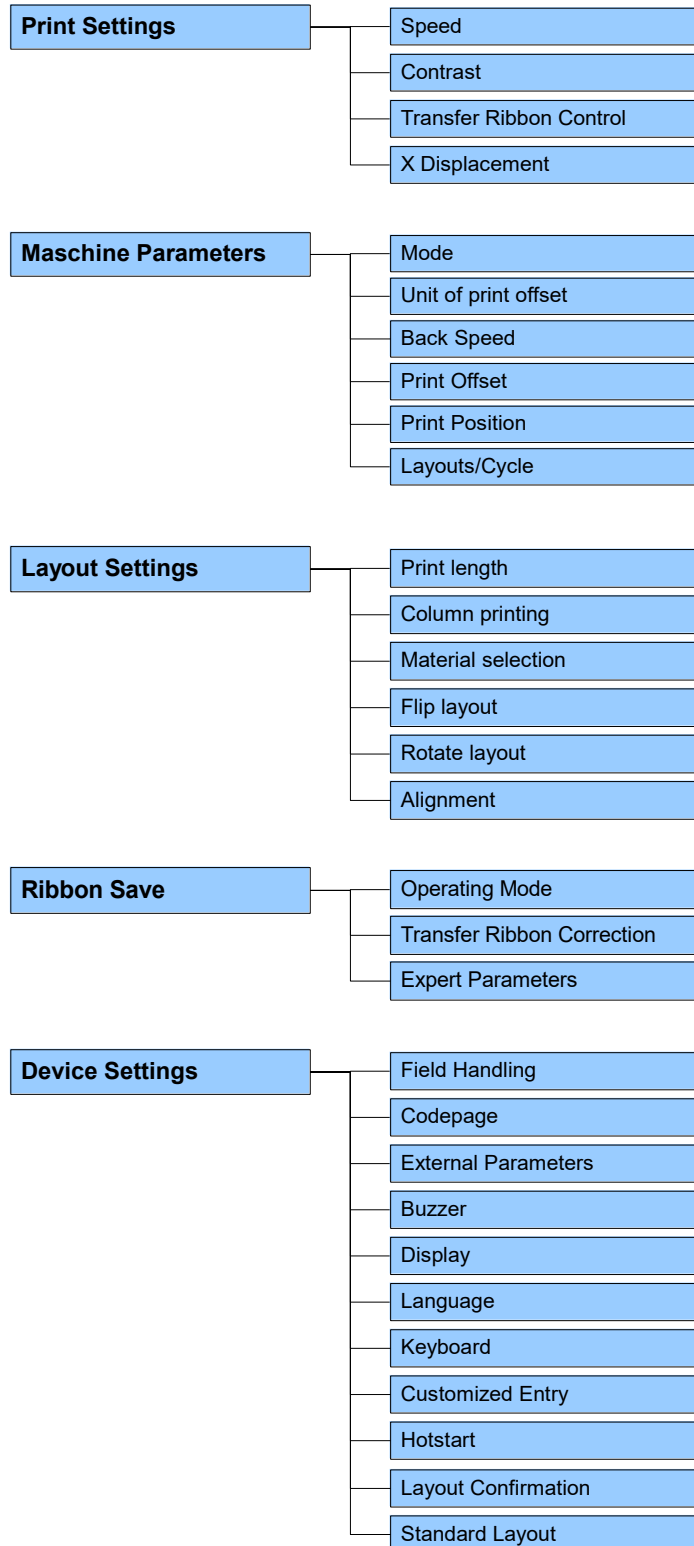

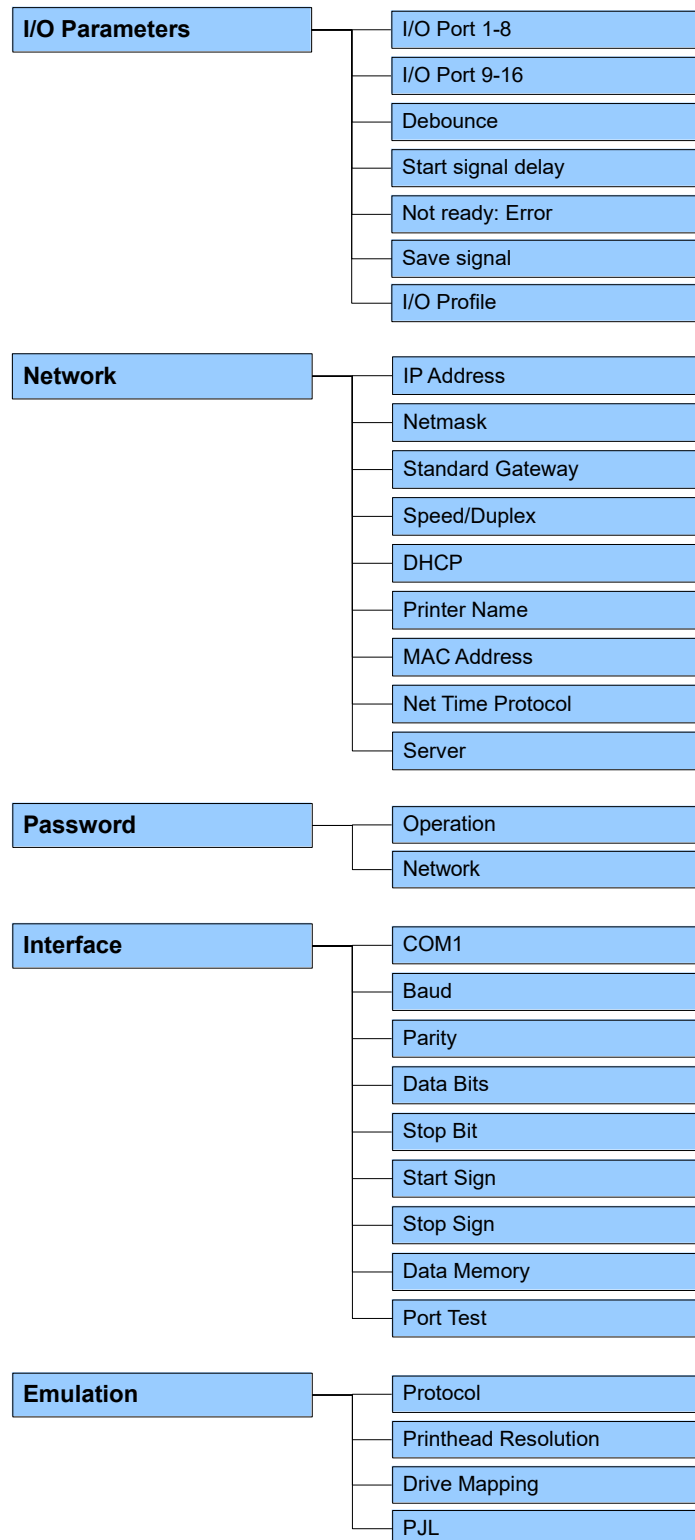

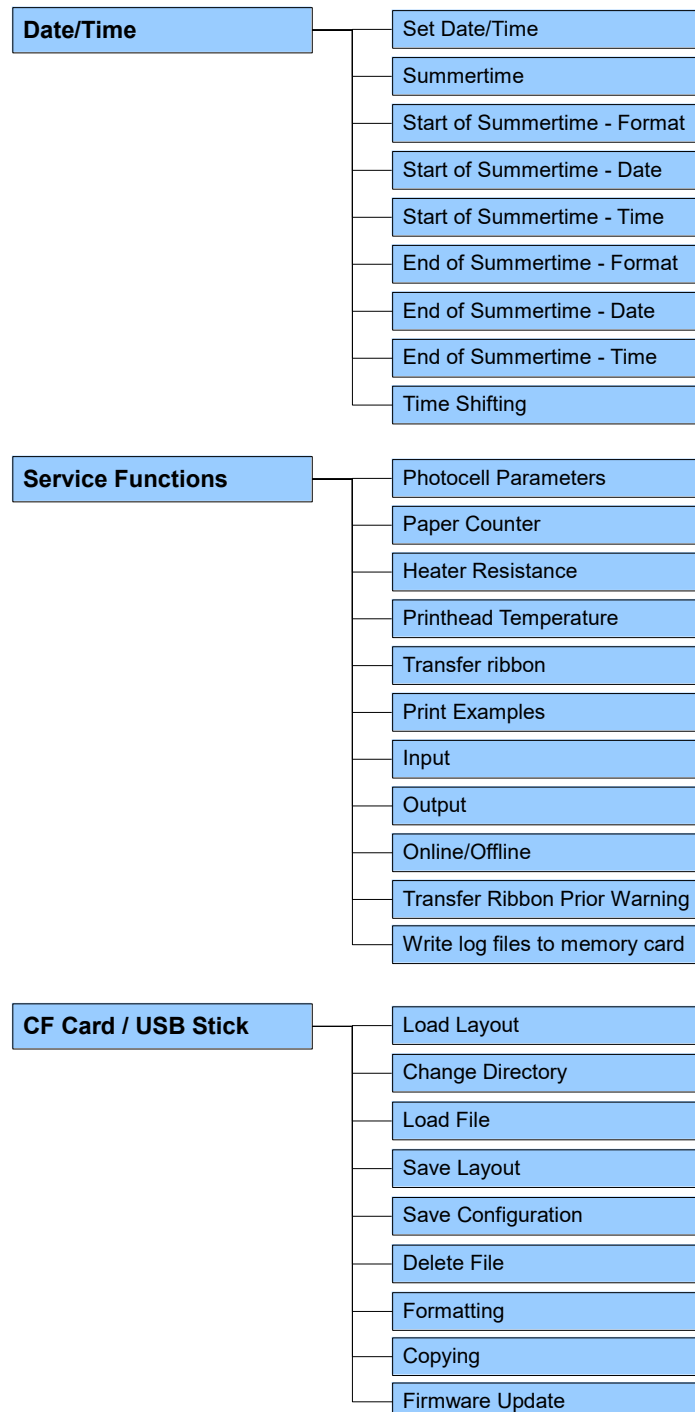



7.3 Print Settings

Switch on the control unit and the display shows the main menu.

Press the key  to access the function menu.

Press the key  to select the menu *Print settings*.

Speed (intermittent mode only)

Indication of print speed in mm/s (see Technical Data, page 19). The print speed can be determined for each print order anew.

The setting of print speed affects also the test prints.

Value range: 50 ... 400 mm/s

Step size: 10 mm/s

Contrast

Indication of value to set the print intensity when using different materials, print speeds or printing contents.

Value range: 10 % ... 200 %.

Step size: 10 %

Press the key  to move to the next menu item.

Ribbon control

Examination if the transfer ribbon roll is empty and/or if the ribbon was torn at the unwinding roll. The current print order is interrupted and an Error Message appears at the printer display.

Off: The ribbon control is deselected, i.e. the printer continues without an error message.

On, weak sensibility (default): The printer reacts at approx. 1/3 more slowly to the end of the transfer ribbon.

On, strong sensibility: The printer reacts immediately to the end of the transfer ribbon.

Press the key  to move to the next menu item.

X displacement

Displacement of the complete print transverse to the paper direction.

The displacement is possible only up to the edges of the printing zone and is determined by the width of the focal line in printhead.

Value range: -90.0 ... +90.0.

7.4 Machine Parameters (Continuous Mode)

Switch on the control unit and the display shows the main menu.



Press the key  to access the function menu.

Press the key  until the menu *Machine parameters* is displayed.

Press the key  to select the menu.

Operating mode

The actual printing process cannot be started via the interface. The machine is always in control mode and the print is released by the control input *Print Start*. The operating mode is normally transferred with each layout otherwise mode *I/O dynamic continuous* is used as standard operating mode.

Press the keys  and  to select the desired operating mode and/or to change the mode. The following modes are available:

IO ST = IO static

The input signal is evaluated, i.e. it is printed as long as the signal exists. The number of layouts, which was entered at print start, is printed (level evaluation of print start signal).

IO ST F = IO static continuous

Corresponds to IO static. Continuous means that not only a defined number of pieces is processed but the same layout is printed as long as new data is transferred by interface.

IO DY = IO dynamic

The external signal is evaluated dynamically, i.e. in case the direct print module is in 'waiting' mode a single layout is printed at each signal changing (flank evaluation of print start signal).

IO DY F = IO dynamic continuous

Corresponds to IO dynamic. Continuous means that not only a defined number of pieces is processed but the same layout is printed as long as new data is transferred by interface.

Unit of print offset

Press the key  to move to the next menu item.

Selection for the unit of print offset.
Settings possible either in mm or ms.

Print offset

Press the key  to move to the next menu item.

Indication of distance of the layout (res. the first layout in case more layouts per cycles are to be printed) to the zero point of machine.

Settings possible either in mm or ms. Place cursor at the mm and/or ms position, press the key  to change between mm and ms.
Value range: 1 ... 999 mm

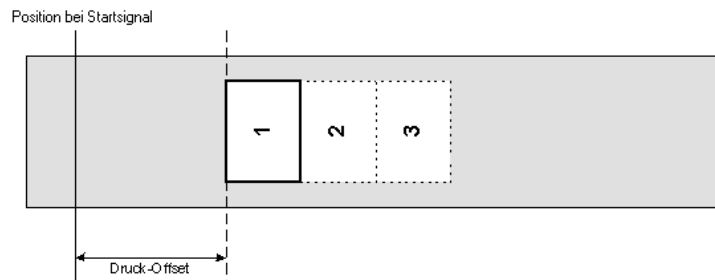
**Print position**

Press the key  to move to the next menu item.

Indication of position of print carriage in mm.
Value range: 12 ... 43 mm

Layouts/cycle

Press the key  to move to the next menu item.

Indication of number of printed layouts per print start (cycle).
Value range: 1 ... 25.

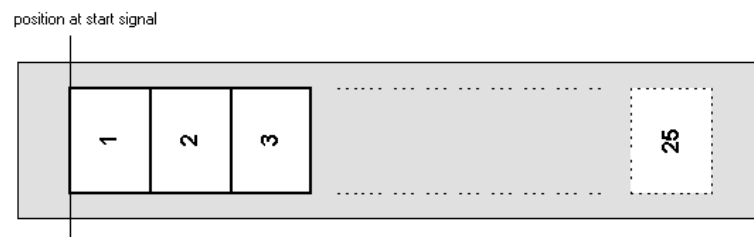
**Check speed on start**

Press the key  to move to the next menu item.

Check material speed at print start signal

Off (Default): Material speed is only checked if the set offset value is taken into consideration. The print start signal can be given although the material is not yet moving. However, until the end the material speed has to be inside the valid speed sector as otherwise the print order is cancelled.

On: Material speed is checked at print start signal. Is the material speed outside of the valid speed sector then the start signal is ignored.

Resolution

Press the key  to move to the next menu item.

Encoder resolution / material feed per encoder rotation

Indication of resolution of used encoder and material feed per rotation of encoder in mm. These settings help measuring the material speed. The material feeding per encoder rotation corresponds for instance, in a 1:1 translation between the encoder and the roller, to the roller circumference.

Press the key  to move to the next menu item.

Material speed

Indication of material speed in mm/s (only for reading purposes). Value range: 12 ... 93 mm/s

7.5 Machine Parameters (Intermittent Mode)

Switch on the control unit and the display shows the main menu.

Press the key  to access the function menu.

Press the key  until the menu *Machine parameters* is displayed.

Press the key  to select the menu.

Mode

Selection of operating mode.

No. of pieces A print order with a defined number of pieces is transferred. After the generating process the target number and the actual number of pieces is shown in the display. A cycle is started via signal input 1 or with the key . With each cycle the actual number of pieces is increased by the number of printed layouts. In case the target number of pieces is reached the print order is finished and the display shows again the main menu.

Continuous A print order is transferred. After the generating process the number of printed layouts is shown in the display. A cycle is started via signal input 1 or with the key . With each cycle the number of printed layouts is increased. The print order is active as long as it is terminated by the user or in case of new data transmission.

Test mode This operating mode corresponds to mode 2. After the return of the print unit to the zero point of the machine, however, internally a further cycle is started (endurance test).

Direct start A print order is transferred. After termination of generating process the print order is executed without an external signal.

Press the key  to move to the next menu item.

Back speed

Indication of back speed of print mechanics after print end in mm/s. Each cycle of the machine consists of printing and return to the zero point of machine. The print speed and back speed can be set separately. The setting range for the back speed is between 50 and 600 mm/s.

Because of this value you can select for low machine clock cycles an operating method which saves the material and increases in this way the life of the printhead.

Because of the mass moment of inertia it could be better to reduce the speed at an installation position of the print unit at $>30^\circ$ horizontal. Value range: 50 ... 600 mm/s.

Press the key  to move to the next menu item.

Unit of print offset

Selection for the unit of print offset. Settings possible either in mm or ms.

Press the key  to move to the next menu item.

Print offset

Indication of distance of the layout (res. the first layout in case more layouts per cycles are to be printed) to the zero point of machine. Value range: 0 ... 999 mm
Default: 0 mm

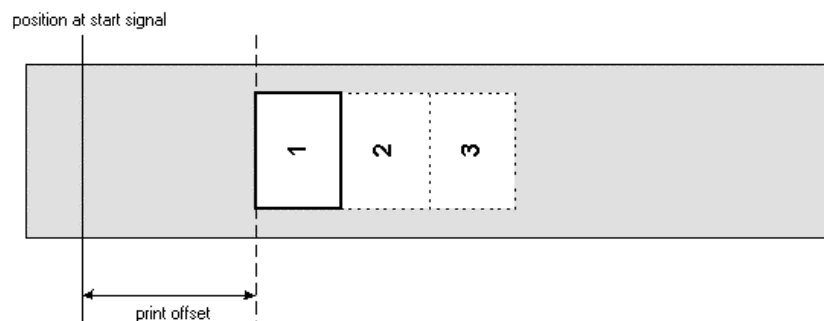

Press the key  to move to the next menu item.

Print position

Indication of start position of print carriage in mm. Value range: 0 ... 43 mm
Default: 3 mm

Press the key  to move to the next menu item.

Layouts/cycle

Indication of the number of printed layouts per print start (cycle). Value range: 1 ... 25.

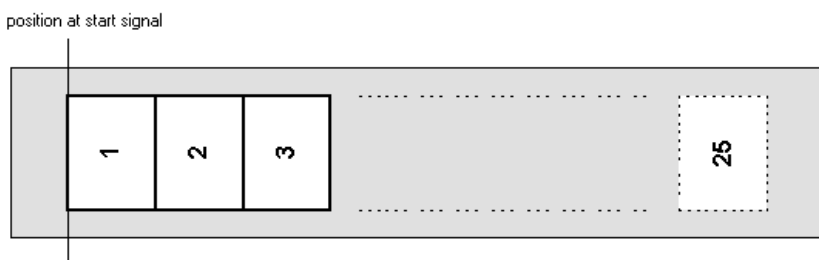

7.6 Layout

Switch on the control unit and the display shows the main menu.

Press the key  to access the function menu.

Press the key  until the menu *Layout* is displayed.

Press the key  to select the menu.

Print length

Indication of the print length in mm.
Indication of way the print mechanics has to move. The print length depends on the length of the print mechanics.

Press the key  to move to the next menu item.

Column printing

Indication of width of one layout as well as how many layouts are placed side by side (see chapter 12.1 Column Printing, page 115).

Press key  to move to the next menu item.

Material selection

Selection of the used transfer ribbon material.

Press the key  to move to the next menu item.

Invert layout

On: The layout is printed inverse.

Off: The function is deactivated.

Press the key  to move to the next menu item.

Flip layout

The axis of reflection is in the middle of the layout. If the layout width was not transferred to the direct print module, automatically the default layout width i.e. the width of the printhead is used. It is recommended to use layouts with the same width as the printhead. Otherwise this can cause problems in positioning.

Press the key  to move to the next menu item.

Rotate layout

According to standard the layout is printed ahead with a rotation of 0°. If the function is activated, the layout is rotated by 180° and printed in reading direction.

Press the key  to move to the next menu item.

Alignment

The adjustment of layout is effected only after *Flip/Rotate layout*, i.e. the adjustment is independent of the functions *Flip layout* and *Rotate layout*.

Left = The layout is aligned at the left-most position of printhead.

Centre = The layout is aligned at central point of printhead.

Right = The layout is aligned at right-most position of printhead.

7.7 Ribbon Save

Ribbon save = maximum exploitation of transfer ribbon

Layout



Transfer ribbon w/o ribbon save

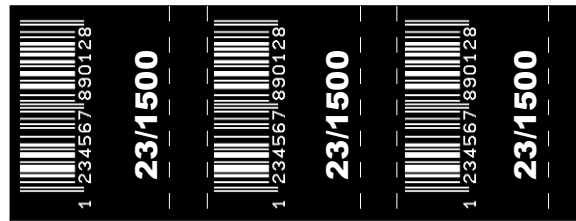

Field ribbon save
Layout ribbon save

Transfer ribbon with ribbon save

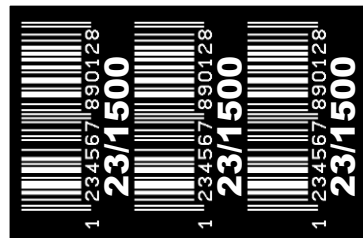

Procedure

In principle the ribbon save is achieved by the way that the transfer ribbon in phases in those no printing is effected stopped or decelerated. If sufficient time is available, the transfer ribbon which was not used for printing can be retracted to print on it afterwards. The possibility of ribbon save and in this way of the print quality are to be connected with the available time which is needed for decelerating and accelerating of transfer ribbon.

There are two different types of ribbon save:

Field ribbon save

It is tried to save transfer ribbon with gaps within the layout. Because of the fact that the gaps are usually very small, only little time is available. Therefore a feedback is not reasonable (lack of time).

Layout ribbon save

The gaps between the layouts are optimised. Usually more time is available here. The loss of transfer ribbon between the layouts which result from accelerating and decelerating of transfer ribbon can be corrected by means of the return.

7.8 Ribbon Save (Continuous Mode)



Switch on the control unit and the display shows the main menu.

Press the key **F** to access the function menu.

Press the key  until the menu *Ribbon save* is displayed.

Press the key  to select the menu.

Mode

Press the keys  and  to select the ribbon save mode 'Standard'.

Standard Maximum ribbon save performance, i.e. with this setting there is no loss of transfer ribbon (apart from the safety distance of 1 mm, so the print fields are not printed one into the other).
No settings are allowed with which the ribbon save no more cannot be achieved. This particularly applies for the print offset, which can only be adjusted now in the valid range.

Press the key  to move to the next menu item.

Speed

Determination of max. print speed.

On the base of this value all necessary calculations e.g. feedback distance and smallest possible print offset are being calculated.

Example

Speed = 400 Very good ribbon save result between
Mode = Standard 50 mm/s ... 400 mm/s.

However, if you print with a speed higher than 400 mm/s, then the ribbon save result is decreased and/or the ribbon save can no longer be executed, because the back-feed way was designed to 400 mm/s. Please consider: if speed is set to 400 and only 300 mm/s are printed, then a smaller number of cycles is reached as if speed is set to 300, however a reserve of 100 mm/s is still available.

Therefore the speed value should be always set to the maximum print speed. If the number of cycles is not sufficient, the rewind correction should be applied.

Press the key  to move to the next menu item.

Transfer ribbon correction

TR Correction

0 mm = It is always so far retracted that an optimal ribbon save is reached (no loss of transfer ribbon). This is rather rarely realised, as the ribbon position can deviate because of inaccuracies at speed measurement (encoder).

Default: -1 mm

-xx mm = The feedback can be made smaller. It causes loss of transfer ribbon but the number of cycles is increased. If the value is increased to the complete backfeed length then the direct print module sets automatically the max. value and no more backfeed is accomplished.

+xx mm = The feedback can be made larger. This causes that it is printed onto the transfer ribbon in the previous printout.

Example

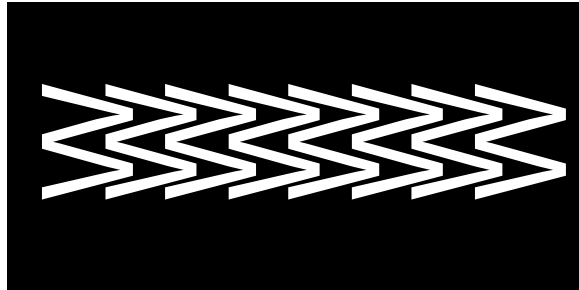

Press the key  to move to the next menu item.

Performance information

sa/mm: The smallest possible distance of two prints with full ribbon save (the print offset must be set to the minimum value). As basis for the calculation the set ribbon save parameters are used, as well as mode and especially the indicated max. print speed.

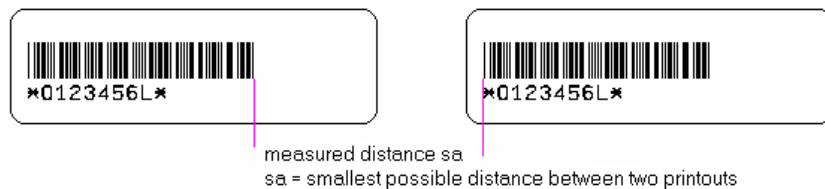

cmin: Max. number of cycles per minute.

so/mm: Indicates the loss of ribbon save, i.e. how many mm transfer ribbon is effectively lost.



Press the key  to move to the next menu item.

Expert parameters

This menu item is password protected. Enter the password, press the key  to confirm the input and the following parameters are indicated:

Printhead down time

PhDownT = printhead down time in ms:

This is used from ribbon save algorithm for the calculation of start time of printhead downwards movement.

Ribbon motor early start time

REStartT = ribbon motor early start time in ms:

This value is added to the acceleration time of transfer ribbon movement. Time indication for the time between 'motor reached material speed' and 'printhead burns'.

If the same value is entered as for PhDownT, the printhead upwards movement is not started before the transfer ribbon motor reached the material speed.

Press the key  to move to the next menu item.

Minimal print speed

MinSpeed = minimal print speed:

If the min. print speed is increased, the max. number of cycles is also increased.

Use max. speed

USMxSped = use maximum speed:

Use the speed parameter as maximum speed. If the material speed exceeds the maximum speed the print is interrupted as long as the material speed is again under the maximum speed.

Press the key  to move to the next menu item.

Printhead up time

PHupT = printhead up time in ms:

Is used from ribbon save algorithm to calculate if a field ribbon save can be made or not.

Valve reaction time

PhVReactT = valve reaction time in ms:

It is calculated when the printhead upwards movement is started.

Press the key  to move to the next menu item.

Print offset border calculation

Calcoff = Turn On/Off print offset border calculation:

If this parameter is set to Off, then a smaller offset as the required print offset can be entered.





Press the key  to move to the next menu item.

Ribbon motor stop delay time

RibMotStpDlayT = ribbon motor stop delay time

Delay time in ms in which the transfer ribbon motor is still moved with constant speed before stopping.

This can be used to correct black bars at the end of print or to provide a longer cooling for the printhead.

	Press the key  to move to the next menu item.
Field ribbon saving	FieldRS = field ribbon saving: Off: Field ribbon save mode Off. PHOnly: Only the printhead is moved. The transfer ribbon is not stopped. Normal: Field ribbon save is executed only if the transfer ribbon motor is completely stopped. Strong: Field ribbon save is executed, even if the transfer ribbon motor is not stopped.
Rewind speed	Rwind v = rewind speed in mm/s: Indication of rewind in mm/s. Press the key  to move to the next menu item.
Ribbon save priority	Ribbon save quality: If the ribbon save algorithm is not able due to fast changes in material speed to keep the demanded ribbon save (ribbon correction) then the printout can be shifted to obtain the demanded transfer ribbon saving Print position: If the ribbon save algorithm is not able due to fast changes in material speed to keep the demanded ribbon save (ribbon correction) then the print position can be kept by an increased transfer ribbon use. Press the key  to move to the next menu item.
Speed 1. Field	If 0 (default value) is set, the parameter has no influence to the ribbon save. Otherwise the ribbon save algorithm does not use the measured speed for the calculation of layout ribbon save but the speed that is indicated here. Press the key  to move to the next menu item.
Tension	Indication of length, which is transported forward after measuring the transfer ribbon. Press the key  to move to the next menu item.
Save start in normal mode	SaveStartInNormMode If a start signal comes during the printing process the print is not interrupted but the print for the start signal is attached directly to the current print.

7.9 Ribbon Save (Intermittent Mode)



Switch on the control unit and the display shows the main menu.

Press the key **F** to access the function menu.

Press the key  until the menu *Ribbon save* is displayed.

Press the key  to select the menu.

Ribbon save mode

Press the key  and  to select the ribbon save mode *Standard*.

Press the key  to move to the first menu item.

Transfer ribbon correction

TR Correction

0 mm = It is always so far retracted that an optimal ribbon save is reached (no loss of transfer ribbon). This is rather rarely realised, as the ribbon position can deviate because of inaccuracies at speed measurement (encoder).

Default: -1 mm

-xx mm = The feedback can be made smaller. It causes loss of transfer ribbon but the number of cycles is increased. If the value is increased to the complete backfeed length then the direct print module sets automatically the max. value and no more backfeed is accomplished.

+xx mm = The feedback can be made larger. This causes that it is printed onto the transfer ribbon in the previous printout.

Example

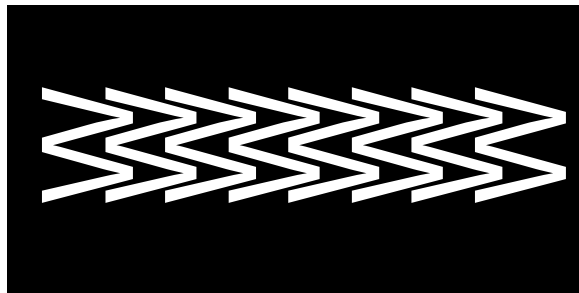

Press the key  to move to the next menu item.

Expert parameters

This menu item is password protected. Enter password, press the key  to confirm the input and the following parameters are indicated:

Printhead down time**PhDownT = printhead down time in ms:**

This is used from ribbon save algorithm for the calculation of start time of printhead downwards movement.

Printhead up time**PhUpT = printhead up time in ms:**

Is used from ribbon save algorithm to calculate if a field ribbon save can be made or not.

Press the key  to move to the next menu item.

Printhead valve reaction time**PhVReactT = valve reaction time in ms:**

It is calculated when the printhead upwards movement is started.

Press the key  to move to the next menu item.

Tension

Tension: Indication of length, which is transported forward after measuring the transfer ribbon.

Ribbon Mode

0 = The transfer ribbon is retracted after each printout over the complete print length, i.e. no ribbon save between the individual layouts.

1 = The transfer ribbon is only retracted over the printed sector, i.e. the gaps between the layouts were not optimised.

When changing the layouts, the transfer ribbon is positioned automatically.

7.10 Device Settings

Switch on the control unit and the display shows the main menu.

Press the key  to access the function menu.

Press the key  until the menu *Device settings* is displayed.

Press the key  to select the menu.

Field handling

Off: The complete print memory is deleted.

Keep graphic: A graphic res. a TrueType font is transferred to the direct print module once and stored in the internal memory of device. For the following print order only the modified data is transferred to the direct print module. The advantage is the saving of transmitting time for the graphic data.

The graphic data created by the direct print module itself (internal fonts, bar codes, ...) is generated only if they were changed. The generating time is saved.

Delete graphic: The graphics res. TrueType fonts stored in the internal memory is deleted but the other fields are kept.

Restore graphic: At the end of the print order the printed order can again be started at the direct print module. All graphics and TrueType fonts are again printed.



NOTICE!

Exception: With column printing always full columns must be printed (number of pieces always multiple of the columns). Deleted columns are not restored.

Press the key  to move to the next menu item.

Codepage

Indication of the font used in the direct print module.

The following possibilities are available:

ANSI character set / Codepage 437 / Codepage 850 / GEM German / GEM English / GEM French / GEM Swedish / GEM Danish.

Press the key  to move to the next menu item.

External parameters

Layout dimension only: The parameters for layout length, gap length and layout width can be transferred to the printing system. All other parameter settings are to be made directly at the printing system.

On: Sending parameters such as speed and contrast via our design software to the printing system. Parameters which are set directly at the printing system before are no longer considered.

Off: Only settings made directly at the printing system are considered.

Press the key  to move to the next menu item.

Buzzer

On: An acoustic signal is audible when pressing a key.
Value range: 1 ... 7.

Off: No signal is audible.

Display

Setting of display contrast.
Value range: 45 ... 75.

Language

Press the key  to move to the next menu item.

Selection of language the display indicates texts in the graphic display. At the moment the following languages are available: German, English, French, Spanish, Finnish, Czech, Portuguese, Dutch, Italian, Danish, Polish, Greek, Hungarian, Russian, Chinese (option), Ukrainian, Turkish, Swedish, Norwegian, Estonian.

Keyboard layout

Press the key  to move to the next menu item.

Selection of region for the desired keyboard layout. The following possibilities are available: German, English, French, Greek, Spanish, Swedish, US American, Russian.

Customized entry

Press the key  to move to the next menu item.

Off: No question appears at the display. In this case the stored default value is printed.

On: The question referring the customized variable appears once before the print start at the display.

Auto: The questions referring the customized variable and the quantity query appear after every printed layout.

Auto without quantity query: The question referring the customized variable appears after every layout without additional query for the quantity.

Hotstart

Press the key  to move to the next menu item.

On: Continue an interrupted print order after switching on the printer anew

Off: No question appears at the display. In this case the stored default value is printed (12.2, page 116).

Autoload

Press the key  to move to the next menu item.

On: A layout which was loaded once from CF card can be loaded again automatically after a restart of printing system.

Procedure: The used layout is saved onto CF card. The layout is loaded from CF card and printed. After switching the printer Off and again On, the layout is loaded from CF card automatically and can be

printed again. Press the key  to start the print with input of number of layouts.

**NOTICE!**

The last loaded layout from CF card is always again loaded after a restart of printer.

Off: After a restart of printer the last used layout must be again loaded manually from CF card.

**NOTICE!**

A common use of the functions Autoload and Hotstart is not possible. For a correct Autoload procedure the Hotstart must be deactivated in the printing system.

Layout confirmation

Press the key  to move to the next menu item.

On: A new print order is only printed after confirmation at the device. An already active continuing print order is printed as long as the confirmation is effected at the device.

Off: No query appears at the display of control unit.

Standard layout

Press the key  to move to the next menu item.

On: If a print order is started without previous definition of layout, the standard layout is printed.

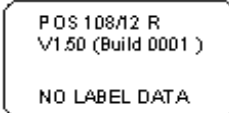



```
P OS 108/12 R
V1.50 (Build 0001 )
NO LABEL DATA
```

Off: If a print order is started without previous definition of layout, an error message appears in the display.

7.11 I/O Parameters

Switch on the control unit and the display shows the main menu.

Press the key  to access the function menu.

Press the key  until the menu *IO parameters* is displayed.

Press the key  to select the menu.

I/O Port 1-8 and I/O Port 9-16

Definition of port functions:
2 sign show the current setting for each port.

The first sign specifies the following:

- I** = Port operates as Input
- O** = Port operates as Output
- N** = Port has no function (not defined)

These settings cannot be modified.

The second sign specifies the following:

- +** = Active signal level is 'high' (1)
- = Active signal level is 'low' (0)
- x** = Port is deactivated
- &** = Function is executed at each change of the signal level
- s** = Status can be enquired/influenced by interface
The printer-internal function is deactivated.

Press the key  to move to the next menu item.

Debounce

Indication of debounce time of the dispenser input. The setting range of the debounce time is between 0 and 100 ms.

In case the start signal is not clear then you can debounce the input by means of this menu item.

Press the key  to move to the next menu item.

Start signal delay (intermittent mode)

Indication in time per second of the delay for the start signal.
Value range: 0.00 ... 9.99.

Press the key  to move to the next menu item.

Not ready: Error

On: If a print order is active but the direct print module is not ready to process the order (e.g. if it is already in 'printing' mode), then an error message appears.

Off: No error message appears.

Speed only: If the print speed falls below the minimum, an error message is displayed.

**Save signal
(intermittent mode)**

Press the key  to move to the next menu item.

On: The start signal for the next label can already be released during printing the current label. The signal is registered from the printing system. The printing system starts printing the next label immediately after finishing the current one. Therefore time can be saved and performance be increased.

Off: The start signal for the next label can only be released if the current label is printed to the end and the printing system is again in 'waiting' state (output 'ready' set). If the start signal was released already before, so this is ignored.

Press the key  to move to the next menu item.

I/O Profile

Selection of the available configurations *Std_Direct* (factory setting), *StdFileSelDirect*, *SP_Direct0* or *Old_Direct0*, *Old_Direct1* or *Old_Direct2*.

The corresponding assignment is indicated in chapter 4.1, page 21.

7.12 Network

Switch on the control unit and the display shows the main menu.

Press the key  to access the function menu.

Press the key  until the menu *Network* is displayed.

Press the key  to select the menu.

IP address

Each participant must have a 32-bit address. The IP address is separated by full stops and arranged into four parts. Each part has a number range of 0 ... 255.

Press the key  to move to the next menu item.

Netmask

In connection with the IP address of the printer, the netmask determines which IP addresses this device searches in the own network.

Press the key  to move to the next menu item.

Standard gateway

The IP address of the network gateway. If the IP address was referred to by DHCP then DHCP is indicated in brackets.

Press the key  to move to the next menu item.

DHCP

DHCP permits the automatic referring of the network parameters IP address, network mask and standard gateway of a DHCP server which must be installed in the network.

Press the key  to move to the next menu item.

Printer name

The name of the installed printer in the network. The printer name in connection with DHCP can be used to respond to the printer. If DHCP is active and the name of the printer is changed, the printer logs out itself at the DHCP server and afterwards the printer logs in again. After changing the printer name, the printer can have a new IP address.

Press the key  to move to the next menu item.

MAC address

The MAC address (Media Access Control) is the hardware address of each individual network adapter and serves for the clear identification of the printer in network.

Press the key  to move to the next menu item.

Net Status Info (password protected)

NoLink: Network cable not plugged in.

LinkOnly: Network cable plugged in; IP configuration incorrect.

FixIP: Network is connected; IP works with a fixed IP.

Search: Waiting for automatic IP assignment.

AutoIP: Network is connected; no DHCP server found; AutoIP is used.

DHCP: Network is connected; DHCP was successful.

Press the key  to move to the next menu item.

Press the key  to confirm the selection.

Network Time Protocol

NTP Active:

On: The NTP function is active

Off: The NTP function is deactivated, i.e. no synchronisation takes place.

NTP Zone:

Value is added to the GMT time of the NTP server.

Press the key  to move to the next menu item.

NTP Serv IP Addr:

IP address of the -NTP server; not the server name.

(e.g. ptbtime1.ptb.de) but only the IP address, e.g. (192.53.103.108).

Press the key  to move to the next menu item.

NTP Status:

Status: 0 = Establishing connection

Status: 1 = Connected

Status: 2 = Error (e.g. server unavailable)

Counter: Counter until next update in seconds.

Interval: Update interval in seconds (default 5 minutes or 300 seconds).

Example

If the counter is set to 250 and the interval to 300, it will take 50 seconds until the next time synchronisation.

Press the key  to move to the next menu item.

NTP Sync Now:

When performing this action, an immediate time synchronisation is performed. This function is used to test the functionality of the NTP server.

Example

Change the time, select the function NTP Sync Now and confirm. The NTP client will set the time correctly again.

Press the key  to move to the next menu item.

Date:

With this function, the NTP function can be tested and controlled.

Time:

With this function, the NTP function can be tested and controlled.

Press the key  to move to the next menu item.

Server

All servers can be enabled or disabled, except those on ports 9100 / 9099.

Parameter Port9100

Spool: Can accept the next connection even when the printers page management is still busy with the previous data. Enables the maximum throughput rate for single print orders.

Simple: If problems occur with the spool setting.

7.13 Password

Switch on the label printer and the display shows the main menu.

Press the key  to access the function menu.

Press the key  until the menu *Password* is displayed.

Press the key  to select the menu.

With a password different functions can be blocked for the operator. There are different applications with which such a password protection can be used reasonably. To receive a most flexible password protection, the printer functions will be divided into several function groups.

Because of these different function groups the password protection is very flexible. The printer can be adjusted best to its actual order, as only certain functions are blocked.

Operation

Password

Entering a 4-digit numeric password.

Press the key  to move to the next menu item.

Protection configuration

Printer settings can be changed (contrast, speed, operating mode, ...). The password protection prevents modifications at the printer settings.

Press the key  to move to the next menu item.

Protection favorites

The password protection prevents the access to the favorites.

Press the key  to move to the next menu item.

Protection memory card

With the functions of the memory card, labels can be stored, loaded, etc. The password protection has to decide if no access or only readable access on CF card is allowed.

No protection: No password protection

Userview only: Only reading access

Protected: Access blocked

Press the key  to move to the next menu item.

Protection Printing

In case the printer is connected to a PC, it can be useful, that the user is not able to produce a print manually. So the password protection prevents that prints can be produced manually.

Press the key  to move to the next menu item.

In order to execute a blocked function, first of all the valid password has to be entered. If the correct password is entered then the desired function can be executed.

Network

Password

Entering a 15-digit password. The password can consists of alphanumeric and special characters.

Press the key  to move to the next menu item.

Protection HTTP

The communication by HTTP can be avoided.

Press the key  to move to the next menu item.

Protection Telnet

The settings of the Telnet service cannot be changed.

Press the key  to move to the next menu item.

Protection remote access

The password protection prevents the remote control of the printer.

Press the key  to move to the next menu item.

In order to execute a blocked function, first of all the valid password has to be entered. If the correct password is entered then the desired function can be executed.

7.14 Interface

Switch on the control unit and the display shows the main menu.

Press the key  to access the function menu.

Press the key  until the menu *Interface* is displayed.

Press the key  to select the menu.

COM1 / Baud / P / D / S

COM1:

0 - serial interface Off.
1 - serial interface On.
2 - serial Interface On, no error message occurs in case of a transmission error.

Baud:

Indication of bits which are transferred per second (speed of data transfer).

Value range: 1200, 2400, 4800, 9600, 19200, 38400, 57600 and 115200.

P = Parity:

N - No parity
E - Even
O - Odd

Please observe that the settings correspond to those of the direct print module.

D = Data bits:

Setting of data bits.
Value range: 7 or 8 Bits.

S = Stop bits:

Indication of stop bits between bytes.
Value range: 1 or 2 stop bits.

Press the key  to move to the next menu item.

Start sign / End sign

SOH: Start of data transfer block → Hex format 01

ETB: End of data transfer block → Hex format 17

Two different start / end signs can be set. The settings are normally SOH = 01 HEX and ETB = 17 HEX. Several host computers cannot process these signs and therefore SOH = 5E HEX and ETB = 5F cannot be set.

Press the key  to move to the next menu item.

Data memory

Standard: After starting a print order the printer buffer receives data as long as it is filled.



Advanced: During a current print order data is received and processed.

Off: After starting a print order no more data is received.

Press the key  to move to the next menu item.

Port test

Check whether the data are transferred via the interface.

Press the keys  and  to select standard (on). Press the key

 and the data sent via any port (COM1, LPT, USB, TCP/IP) is printed.

7.15 Emulation

Switch on the control unit and the display shows the main menu.

Press the key  to access the function menu.

Press the key  until the menu *Emulation* is displayed.

Press the key  to select the menu.

Protocol

CVPL: Carl Valentin Programming Language

ZPL: Zebra® Programming Language

Change between CVPL protocol and ZPL II® protocol.

Press the key  to confirm the selection.

The direct print module performs a restart and ZPL II® commands are transformed into CVPL commands internally by the direct print module and then executed by the device.

In menu Protocol, press the key  to move to the next menu item.

Printhead resolution

At activated ZPL II® emulation the printhead resolution of the emulated device must be set, e.g. 11.8 Dot/mm (= 300 dpi).



NOTICE!

If the printhead resolution of the Zebra® printer differs from that of the Valentin device, then the size of objects (e.g. texts, graphics) complies not exactly.

Press the key  to move to the next menu item.

Drive mapping

The access to Zebra® drives

B: CF card

E: Flash drive

R: RAM disk (standard drive, if not indicated)

is rerouted to the corresponding Valentin drives

A: CF

R: RAM disk

U: USB stick

This can be necessary if the available space on the RAM disk (at present 512 KByte) is not sufficient or if bitmap fonts are downloaded to the device and be stored permanently.



NOTICE!

As the build-in fonts in Zebra® printers are not available in Valentin devices this can cause small differences in the text image.

Press the key  to move to the next menu item.

PJL (Printer Job Language)

The processing of PJL commands (Hewlett Packard® Print Job Language) can be switched On/Off. Status information relating to the print order can be queried.

7.16 Date & Time



Switch on the control unit and the display shows the main menu.



Press the key  to access the function menu.

Press the key  until the menu *Date/Time* is displayed.

Press the key  to select the menu.

Setting of date and time

The upper line of display shows the current date, the second line the current time. Press the key  or  to move to the next input field.

Press the key  or  to increase or decrease the figures at the cursor position.

Press the key  to move to the next menu item.

Summertime

On: Device automatically adjust clock for daylight saving changes.

Off: Summertime is not automatically recognized and adjusted.

Press the key  to move to the next menu item.

Start of summertime – Format

Select the format in which you want to define beginning summertime. The above example indicates the default setting (European format).

DD = day	WW = week	WD = weekday
MM = month	YY = year	next day = only next day is taken into consideration

Press the key  to move to the next menu item.

Start of summertime – Date

By means of this function you can enter the date at which summertime has to start. This entry refers to the previously selected format.

Press the key  to move to the next menu item.

Start of summertime – Time

By means of this function you can define the time when you want to start summertime.

Press the key  to move to the next menu item.

End of summertime – Format

Select the format in which you want to define end of summertime. The example above indicates the default setting (European format).

Press the key  to move to the next menu item.

End of summertime – Date

By means of this function you can define the date when you want to stop summertime. The entry refers to the previously selected format.

Press the key  to move to the next menu item.

End of summertime – Time

By means of this function you can define the time when you want to stop summertime.

Press the key  to move to the next menu item.

Time shifting

By means of this function you can enter time shifting in hours and minutes (for automatically adjustment from summer and wintertime). This entry refers to the currently set device time.

7.17 Service Functions



NOTICE!

So that the distributor res. the manufacturer in case of service can offer fast support the necessary information such as selected parameters can be taken directly from the service functions menu of the device.

Switch on the control unit and the display shows the main menu.

Press the key to access the function menu.

Press the key until the menu *Service functions* is displayed.

Press the key to select the menu.

Photocell parameters

- H** = Cover switch
Available only if cover switch is available.
0 = cover open
1 = cover closed.
- P** = Pressure
Indication of 0 or 1 for the compressed-air control.
- R1** = not used
- R2** = Transfer ribbon unwinding roll
Indication of value 0 to 3 for the status of transfer ribbon unwinding roll. 4 possibilities are indicated (no marking in photocell, marking from right, marking from left, marking completely in photocell).
- E** = Encocer
Indication of current state of encoder
- C** = Carriage
Indication of print carriage position.

Press the key to move to the next menu item.

Paper counter

D: Indication of printhead attainment in meters.

G: Indication of device attainment in meters.

Press the key to move to the next menu item.







Heater resistance

To achieve a high print quality, the indicated Ohm value must be set after replacing the printhead.

Press the key to move to the next menu item.

Printhead temperature

Indication of printhead temperature. The printhead temperature corresponds normally to the room temperature. In case the maximum printhead temperature is exceeded, the current print order is interrupted and an error message appears at the display.

- Press the key  to move to the next menu item.
- Ribbon**
Selection of the used transfer ribbon length (300 m, 450 m, 600 m).
With smaller ribbons, a higher number of cycles can be reached.
- Press the key  to move to the next menu item.
- Print examples**
- Settings** = Printout of all printer settings such as speed, layout and transfer ribbon material.
- Bar codes** = Printout of all available bar code types.
- Fonts** = Printout of all available font types.
- Press the key  to move to the next menu item.
- Input**
Indication of input signal level which depends on the set *I/O Profile* (see page 24).
0 = Low
1 = High
- Press the key  to move to the next menu item.
- Output**
Indication of signal level which depends on the set *I/O Profile* (see page 24).
0 = Low
1 = High
- Press the key  to move to the next menu item.
- I/O Status**
Relevant results are counted and registered in RAM memory. The protocols get lost after switching off the device.
- RInt** = Real Interrupts
The start input impulses are counted directly at the Interrupt.
- Dbnc** = Debounced
The start input impulses that are longer than the set debounce time are counted. Only these start impulses can lead to a print. If a start impulse is too short, no print is released. This is recognized by the fact that RInt is counted, Dbnc not.
- NPrn** = Not Printed
The debounced start input impulses that have not led to a print are counted. Causes: no active print order, print order stopped (manually or because of an error) or the printing system is still active with the processing of a print order.
- PrtStrtReset** = The counters are reset.
- PrtStrtTime** = Measured length of the last start impulse in ms.
- Press the key  to move to the next menu item.
- Online / Offline**
This function is activated e.g. if the transfer ribbon is to be changed. It is avoided that a print order is processed although the module is not ready. If the function is activated then press the key  to change between Online and Offline mode. The respective state is indicated in the display.
Standard: Off

Online: Data can be received by interface. The keys of the foil keyboard are only active, if you changed in the Offline mode with the key .

Offline: The keys of the foil keyboard are still active but received data are not processed. If the module is again in Online mode then new print orders can be again received.

Press the key  to move to the next menu item.

Transfer ribbon advance warning

Before the end of transfer ribbon, a signal is send by the control output.

Warning diameter

Setting of transfer ribbon advance warning diameter.

In case you enter a value in mm then a signal appears via control output when reaching this diameter (measured at transfer ribbon roll). Value range: 0 ... 255 mm

Ribbon advance warning mode

Warning: When reaching the transfer ribbon advance warning diameter, the corresponding I/O output is set.

Error: The printing system stops when reaching the transfer ribbon advance warning diameter with the message 'too less ribbon'.

Press the key  to move to the next menu item.

Write log files to memory card

The printing system logs different events internally. In case of service, the error cause can be located faster.

With this command, different log files are saved on an existing storage medium (memory card or USB stick). After the 'Finish' message the storage medium can be removed.

The files are in directory 'log':

LogMemErr.txt: Logged errors with additional information such as date/time and file name/line number (for developers).

LogMemStd.txt: Logging of selected events.

LogMemNet.txt: Data latest send via port 9100.

Parameters.log: All printer parameters in human readable form.

TaskStatus.txt: Status of all printer tasks.

The files *LogMemErr.txt* and *LogMemStd.txt* are written in circle, i.e. old contents are overwritten. The entry logged last is marked with „---„

7.18 Main Menu

Switch on the control unit and the display shows the main menu. The main menu shows information such as device type, current date and time, version number of firmware and the used FPGA.

The selected display is shown for a short time, then the indication returns to the first information.

Press the key  to move to the next information display.

7.19 Display During Printing

```
TESTETI: wait
printed: 00000
```

The direct print module is in 'waiting' mode, i.e. ready to receive data.

Press the key  to interrupt an active print order.
The display shows the following:

```
TESTETI: ST 0
printed: I00000
```

Press the key  key to continue the interrupted print order.

In case an active print order was interrupted by means of key 

and afterwards the key  pressed, then the print order was cancelled and the direct print module changes to the main menu.

```
Material speed
  300 mm/s
```

During the print order the number of layouts which already printed is indicated. Press the key  to move to the menu item *Material speed*.

```
Print offset
(mm)      10.0
```

Press the key  to move to the menu item *Print offset*. The print offset can be changed during the running print order.

Press the key  and the direct print module changes again to the initial position, i.e. to the 'waiting' mode.

8 Compact Flash Card / USB Memory Stick

8.1 General Information

On the back side of the label printer is the slot for the CF card and the USB port for inserting the USB memory stick.

The mass storage menu (memory menu) permits the access to CF cards or USB memory sticks attached to the printer. Among loading and saving labels simple operations of contents are possible such as delete files/directories, copy files/directories or formatting.



NOTICE!

In case of a malfunction of the original memory medium it is recommend to copy the most important data by means of a commercial Card Reader.

8.2 Display Structure

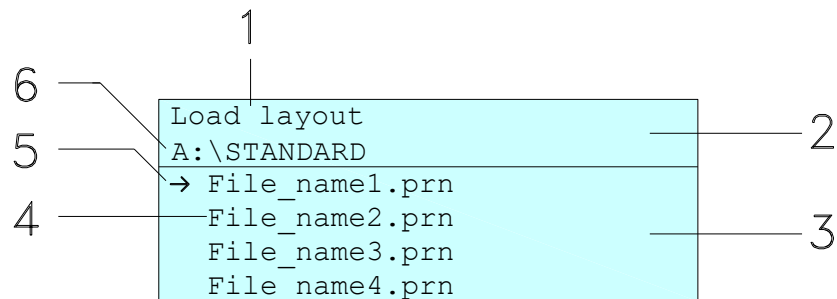

1 = Current function

2 = 2-lined header

3 = Scroll range

4 = File names / directory names

5 = Marking of the selected file (cursor)

6 = Current path (drive:\directory)

The two-line header (2) contains the current function name (1) and the current path (6).

The four-line scroll range indicates a list of files/directories. The first entry (marked with an arrow) is the active one. To this file/directory and/or these files/directories refer all actions.



NOTICE!

Three drives are available.



















A:\ indicates the CF card.

U:\ indicates the USB memory stick.
(only one stick can be inserted)

R:\ indicates the RAM (ZPL Emulation).

8.3 Navigation

The memory menu is operated with the keys of the foil keyboard of the control unit or with different function keys of an attached USB keyboard.

		Return to the previous menu.
		Function <i>Load layout</i> : Change to the File Explorer. File Explorer: Change to the 'context menu'.
		Select a file/directory if a multiple selection is possible.
		Main menu: Access to the memory menu. File Explorer: Create a new file.
		Start the current function for the active file/directory.
		Change to the superordinate directory.
		Change to the currently marked directory.
		In the current directory scroll upwards.
		In the current directory scroll downwards.

8.4 Define User Directory



NOTICE!

A user directory is to be defined:

- before using and/or navigating through the memory menu.
- if formatting of CF card is effected at PC and thus the STANDARD directory was not created automatically.

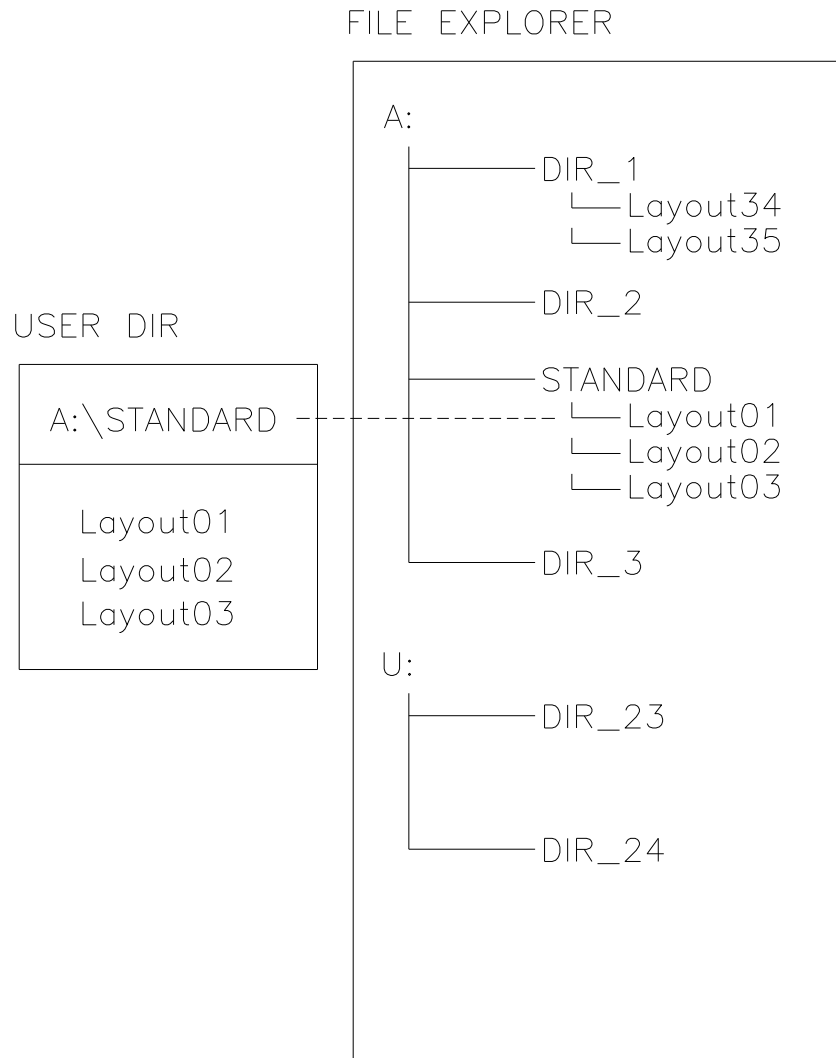

The user directory is the root directory in which the user saves usually the most frequently used files/layouts. The utilisation of the user directory permits the quick and direct access to the files saved in the defined user directory. The definition of a user directory saves thus a long search of the file to be printed.

Press the key  to access the memory menu.

Press the key  to call the File Explorer.

<pre>File Explorer A:\ [Drives] -><STANDARD> <DIR_1></pre>	<pre>Context Menu A: ->Set as user dir Format Copy</pre>
--	---

Press the keys , , ,  to select the directory.

Press the key  to display all available functions.

Select the function *Set as user dir* and press the key  to confirm the selection.

Press the key  until the printer is back in the main menu.





At the next start of the memory menu the selected directory is displayed as user directory.

8.5 Load Layout

Loads a layout within a defined user directory. The function allows quick access to the desired layout as only layout files are displayed and directories hidden.

```
Load layout
A:\STANDARD
->File_name1.prn
File_name2.prn
File_name3.prn
File_name4.prn
```

Press the key  to access the memory menu.

Press the keys , , ,  to select the layout to be printed.

Press the key  to confirm the selection.

The printer display shows automatically the window to insert the number of copies which are to print.

Select the number of copies which are to be printed.

Press the key  to start the print order.



NOTICE!

The directory can NOT be changed here. A change of directory MUST be made in the File Explorer with the function *Change directory*.

8.6 File Explorer

The File Explorer is the file manager of the printing system. The File Explorer provides the main functions for the user interface of memory menu.

In the user directory, press the key **F** to access the File Explorer.

Following functions are available:

- Change drive and/or directory
- Load file
- Save layout and/or configuration
- Delete file(s)
- Format CF card
- Copy file(s)

Change drive/directory

Selection of drive and/or directory in which the files are saved.

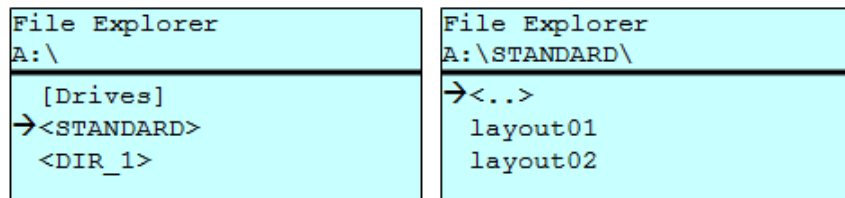

Press the key **F** to access the memory menu.

Press the key **F** to call the File Explorer.

Press the keys **↑**, **↓**, **←**, **→** to select the directory.

Press the key **Enter** to confirm the selection.

The selected directory is now displayed.



Load file

Loads a file. This can be a configuration saved before, a layout, etc.

```
Load file
A:\STANDARD\
<..>
→ layout01
  layout02
```

Press the key  to access the memory menu.

Press the key  to call the File Explorer.

Press the keys  and  to select the file.

Press the key  to load the selected file.

If the selected file is a layout, then the number of copies to print can be entered immediately.

Save layout

Saves the currently loaded layout under the selected name.

```
Save file
A:\STANDARD
→ Save layout
  Save config.
noname
```

Press the key  to access the memory menu.

Press the key  to call the File Explorer.

Press the key  to move to the menu *Save file*.

Select the function *Save layout* and press the key  to confirm the selection.

If an USB keyboard is attached a new file name for *noname* can be assigned.

Save configuration

Saves the complete, current printer configuration under the selected name.

```
Save file
A:\STANDARD
Save layout
→Save config.
config.cfg
```

Press the key  to access the memory menu.

Press the key  to call the File Explorer.

Press the key  to move to the menu *Save file*.

Select the function *Save configuration* and press the key  to confirm the selection.

If an USB keyboard is attached a new file name for *config.cfg* can be assigned.

Delete file(s)

Deletes one or more files and/or directories irrevocably. With the deletion of a directory both the contained files and the subdirectories are deleted.

File Explorer A:\STANDARD\ layout01 * →layout02 * layout03 layout04	Context menu 2 objects marked →Delete Copying
--	--

Press the key  to access the memory menu.

Press the key  to call the File Explorer.

Press the keys  and  to select the file.

Press the key  to mark the files which are to be deleted. The marked entries are listed with *. Repeat this procedure until all desired files and/or directories are marked for deletion.

Press the key  to call the context menu.

Select the function *Delete* and press the key  to confirm the selection.

**NOTICE!**

The deleting procedure is irreversible!

Format memory card

Formats irrevocably the memory card.

**NOTICE!**

USB sticks cannot be formatted at the printer!

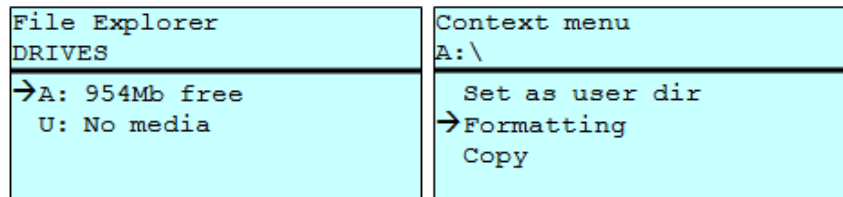

Press the key  to access the memory menu.

Press the key  to call the File Explorer.

Select the drive which is to format with the navigation keys.

Press the key  to call the context menu.

Select the function *Format* and press the key  to confirm the selection.

Copy memory card

Creates a duplicate of the original file and/or the original directory to make changes independently of the original.

File Explorer A:\STANDARD\ layout01 * → layout02 * layout03 layout04	Context menu 2 objects marked Delete → Copying
---	---

Press the key  to access the memory menu.

Press the key  to call the File Explorer.

Press the keys  and  to select the file.

Press the key  to mark the files which are to be copied. The marked entries are listed with *. Repeat this procedure until all desired files and/or directories are marked for copying.

Press the key  to call the context menu.

Select the function *Copy* and press the key  to confirm the selection.

Select Destination DRIVES → A: 954Mb free

Select the target storage with the navigation keys and press the key  to confirm the selection.

8.7 Firmware Update

Starting from firmware version 1.58, updates can be performed via the memory menu. Both the USB stick as well as the CF card can be used for this.

Procedure

On the CF card / USB memory stick a directory is created in which the necessary update files are stored (firmware.prn, data.prn). By means of the function *Load file* the file *firmware.prn* is selected/loaded. In the first step the printer executes the firmware update. After the necessary restart automatically the file *data.prn* is loaded. In this way the remaining components were updated. is After a renewed restart the update procedure is finished.

8.8 Filter

For certain functions a filter mask or a file name of a file which is to be saved can be entered. This input is indicated in the path line. The filter mask can be used to search for specific files. For example, with the input of 'L' only the files are listed whose character string starts with 'L' (regardless of upper and lower cases).

Without filter

```
Load layout
A:\STANDARD
→First_file.prn
  Layout_new.prn
  Sample.prn
  12807765.prn
```

With filter

```
Load layout
L
→Layout_new.prn
```

9 Maintenance and Cleaning



DANGER!

Risk of death by electric shock!

⇒ Before opening the housing cover, disconnect the printing system from the mains supply and wait for a moment until the power supply unit has discharged.



CAUTION!

Risk of injury when cleaning.

⇒ Pay attention to sharp edges.



NOTICE!

When cleaning the label printer, personal protective equipment such as safety goggles and gloves are recommended.

Maintenance plan

Maintenance task	Frequency
General cleaning (see section 9.1, page 90).	As necessary.
Clean the transfer ribbon drawing roller (see section 9.2, page 90).	Each time the transfer ribbon is changed or when the printout is adversely affected.
Clean the printhead (see section 9.3, page 89).	Each time the transfer ribbon is changed or when the printout is adversely affected.
Replace the printhead (see section 9.4, page 92).	In case of errors in printout.



NOTICE!

The handling instructions for the use of Isopropanol (IPA) must be observed. In the case of skin or eye contact, immediately wash off the fluid thoroughly with running water. If the irritation persists, consult a doctor. Ensure good ventilation.

9.1 General Cleaning



CAUTION!

Abrasive cleaning agents can damage the direct print module!

- ⇒ Do not use abrasives or solvents to clean the outer surface of the direct print module.
- ⇒ Remove dust and paper fuzz in the printing area with a soft brush or vacuum cleaner.
- ⇒ Clean the outer surfaces with an all-purpose cleaner.

9.2 Clean the Transfer Ribbon Drawing Roller

A soiled drawing roller can lead to reduced print quality and can affect transport of material.

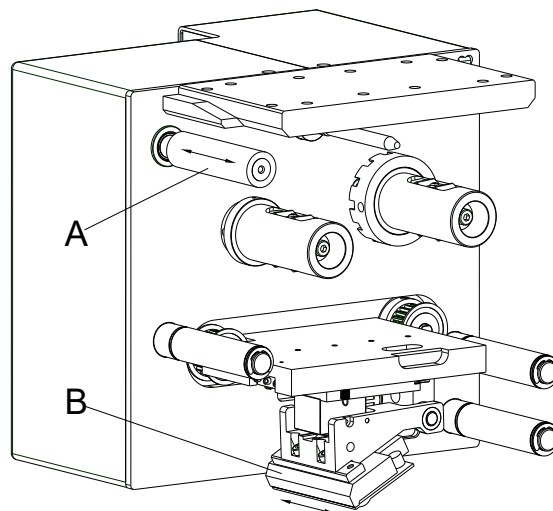

Figure 18

1. Remove the cover.
2. Remove transfer ribbon from the direct print module.
3. Remove deposits with the roller cleaner and a soft cloth.
4. If the roller (A) appears damaged, replace it.
5. Insert again the transfer ribbon material.
6. Reinstall the cover.

9.3 Clean the Printhead

**CAUTION!**

Risk of injury from the hot printhead!

- Make sure the printhead has cooled down before cleaning.

Printing can cause accumulation of dirt at printhead e.g. by colour particles of transfer ribbon, and therefore it is necessary to clean the printhead in regular periods depending on operating hours, environmental effects such as dust etc.

**CAUTION!**

Printhead can be damaged!

- ⇒ Do not use sharp or hard objects to clean the printhead.
- ⇒ Do not touch the protective glass layer of the printhead.

1. Remove the cover.
2. Clean the printhead surface (B, Figure 18) with a special cleaning pen or a cotton swab dipped in pure alcohol.
3. Before using the printing system, let the printhead dry for about two to three minutes.
4. Reinstall the cover.

9.4 Replace the Printhead



CAUTION!

The printhead can be damaged by static electricity discharges and impacts!

- ⇒ Set up the device on a grounded, conductive surface.
- ⇒ Ground your body, e.g. by wearing a grounded wristband.
- ⇒ Do not touch the contacts on the plug connections.
- ⇒ Do not touch the printhead with hard objects or your hands.

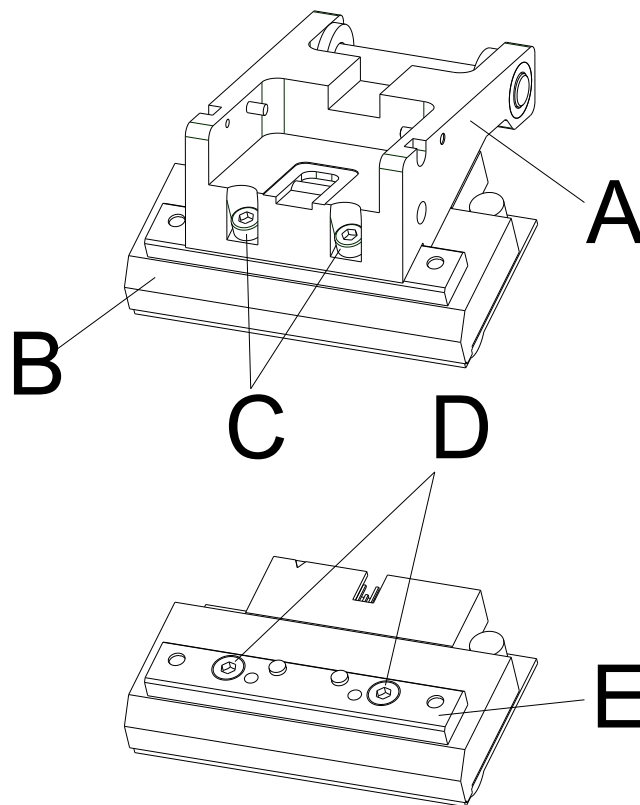
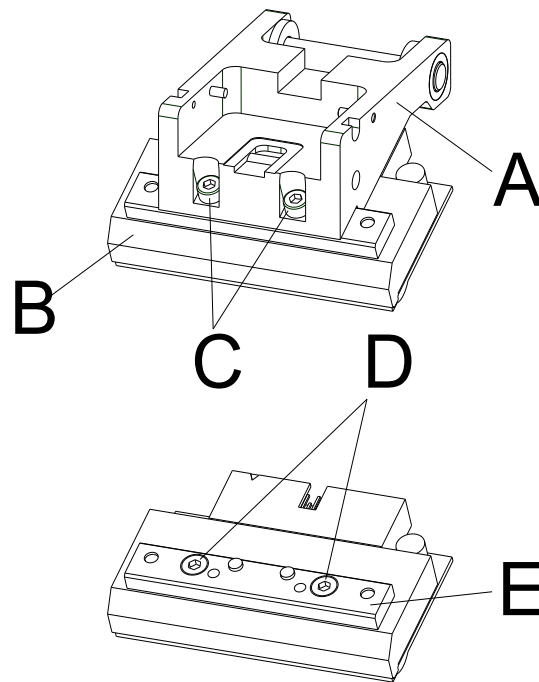

Figure 19

Remove the printhead

1. Remove the cover.
2. Move the printhead unit in an appropriate service position.
3. Press the printhead support (A) slightly downwards until an Allen key can be inserted in the screws (C).
4. Unscrew the screws (C) and remove the printhead (B) with the printhead flat rod (E).
5. Remove connection at the rear of the printhead.
6. Remove the screws (C) and afterwards the printhead (B).

**Figure 20****Install the printhead**

1. Fix the printhead flat rod (E) with the screws (C) to the printhead. Ensure the correct position of the flat rod (see illustration).
2. Insert the connection assembly to the new printhead.
3. Position the printhead (B) in the printhead support (A), so the engaging pieces catch in the appropriate holes in the printhead support (A).
4. Hold the printhead holder (A) with a finger slightly on the pressure roll and check the correct position of the printhead (B).
5. Screw in the screw (C) and tighten it with an Allen key.
6. Insert again the printhead cable.
7. Insert the transfer ribbon (see chapter 5.8, page 38).
8. Reinstall the cover.
9. Enter the resistance value of the new printhead in the menu *Service Functions/Heater resistance*. The value is indicated on the type plate of printhead.
10. Start a test print to check the printhead position.

9.5 Angle Adjustment (Intermittent Mode)

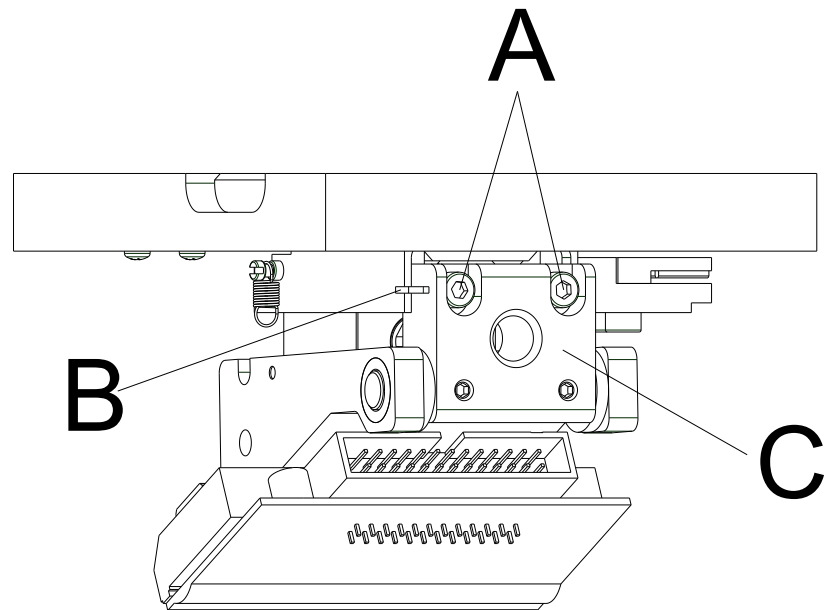

Figure 21

The installation angle of the printhead is default 26° to the print surface. However, manufacturing tolerances of printhead and mechanics can require another angle.



CAUTION!

Damage of printhead by unequal use!

Higher wastage of ribbon by faster ripping.

⇒ Only change the factory settings in exceptional cases.

1. Loosen slightly the Allen head screws (A).
2. Move the adjusting part (C) to adjust the angle between the printhead and printhead support.
move downwards = decrease angle
move upwards = increase angle
3. Tighten again the Allen head screws (A).
4. Start a print order with approx. three layouts to check the correct unwrinkled ribbon run.



NOTICE!

The slots (B) serve for position control. Pay attention to a parallel adjustment.

9.6 Print Quality Optimisation

The following table shows some possibilities to improve the print quality. Generally you have to note: the higher the print speed the lower the print quality.

Problem	Possible solution
Regular inferior print quality	<ul style="list-style-type: none"> • Increase the contrast • Increase the pressure • Reduce the print speed • Reduce the transfer ribbon speed • Reduce the distance between printhead and print surface • Change the combination of transfer ribbon and print medium • Control the print surface (hardness) • Change the printhead angle
Partial inferior print quality (on one side)	<ul style="list-style-type: none"> • Align the surface parallel to printhead • Set regular the transfer ribbon tension • Set regular the printhead angle
Partial inferior print quality (periodical)	<ul style="list-style-type: none"> • Sand and smooth the surface • Reinforce the surface against bending

9.7 Cycle optimisation (Intermittent Mode)



NOTICE!

Number of cycle is a complete print cycle per time unit.

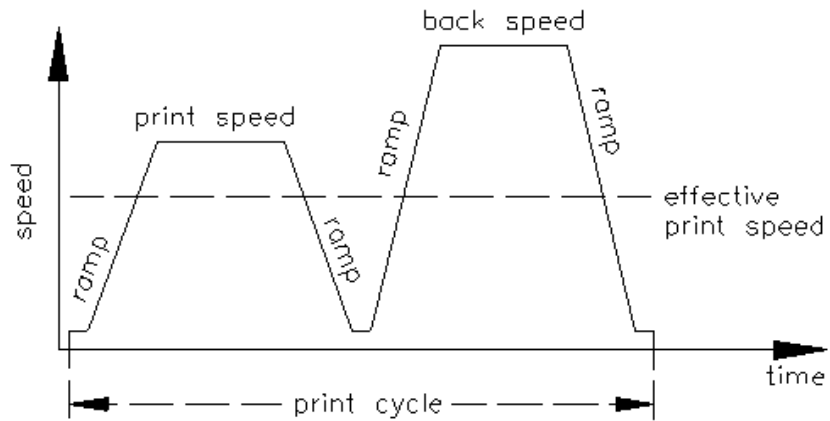

Figure 22

In case of 'time critical' applications you have the possibility with a good selection of different device parameters to increase the effective print speed and in this way the clock cycle.

- Generally increase the print speed.
- Generally increase the back speed.
- Increase acceleration and brake ramp.
- Change the zero point of machine.
- Avoid vertical installation position of the print mechanics. Install the machine in horizontal position.
- Ensure a short distance between the printhead and print surface.
- Switch off the ribbon save function.
- Optimise the layout to a short print way, i.e. less blanks, no borders at the top res. bottom, rotate the layout.

10 Signal Diagrams

10.1 Continuous Mode



NOTICE!

The line 'data receipt' indicates when the direct print module receives data.

Dispenser mode: Dynamic

Number of layouts per print order: 1
Data memory: standard
Ribbon save: On
Trigger input print start: increasing slope

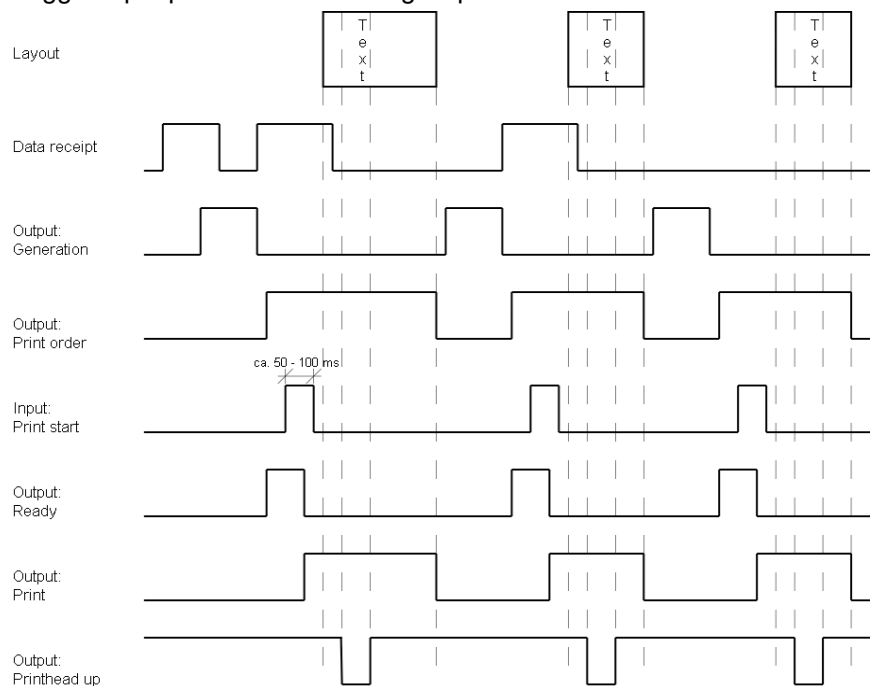

Layout

In 'dispenser mode: dynamic' the layout distance onto the material is not determined by the layout length but by the time between start impulse and print start input.

Because of the fact that the setting 'data memory: standard' the next print order is generated after the previous one is finished and a print order is only finished after the feed of the complete layout, the smallest possible time between two start impulses depends also from the layout length.

In case the printable data is only at the beginning of the layout and the rest of the layout is empty, then the time of start impulse by minimising the layout length (not for 'data memory: extended') can be decreased.

Data receipt

As soon as the generation of a layout is finished, a new one is send to the direct print module. The time of receipt for the first layout is normally shorter because at this time the direct print module has no further action. At receipt of the following layout, the time of receipt is longer because the direct print module receives data and prints at the same time.

Number of layouts per print order: 1
 Data memory: extended
 Ribbon save: On
 Trigger input print start: increasing slope

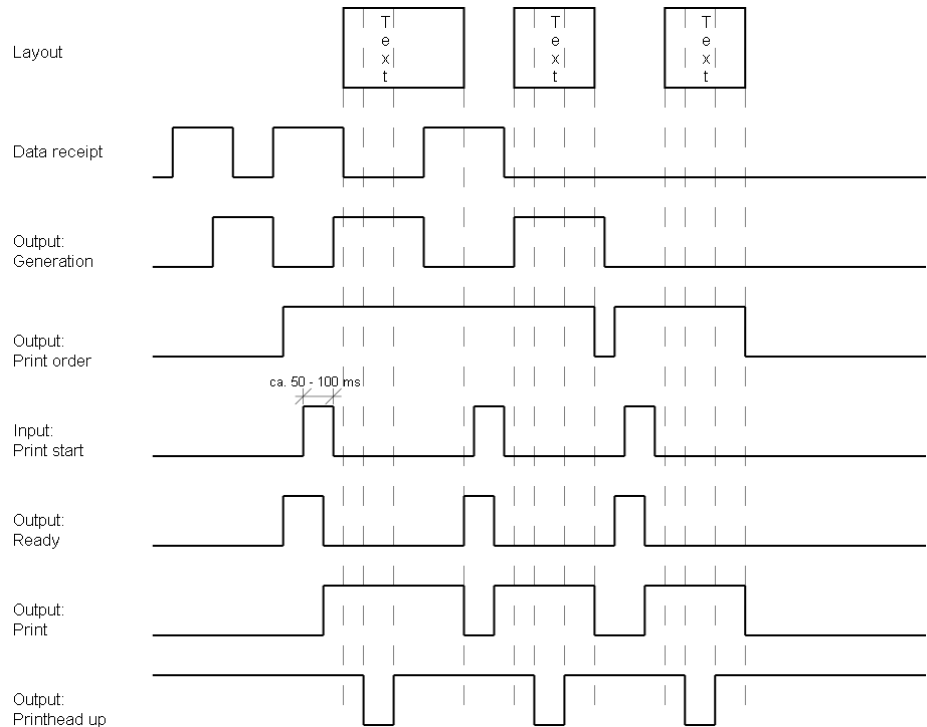

Layout

For a better comparison we used the same layouts as before.

Data receipt

As soon as the generation of the layout is finished a new one is send to the direct print module.

Data receipt/ generation

The time of receipt for the first layout is normally shorter because at this time the direct print module has no further action. At receipt of the following layout, the time of receipt is longer because the direct print module receives data and prints at the same time.

Generation

In mode 'data memory: extended' already received data is always generated after the start of a print order.

Print order

Before the current print order is finished the next one is already generated. The signal output is therefore active and the next start impulse can be send.

Print

Before the next start impulse is send, the print has to be finished as otherwise the impulse is ignored.

Number of layouts per print order: 3
 Data memory: Off/standard/extended
 Ribbon save: On
 Trigger input print start: increasing slope

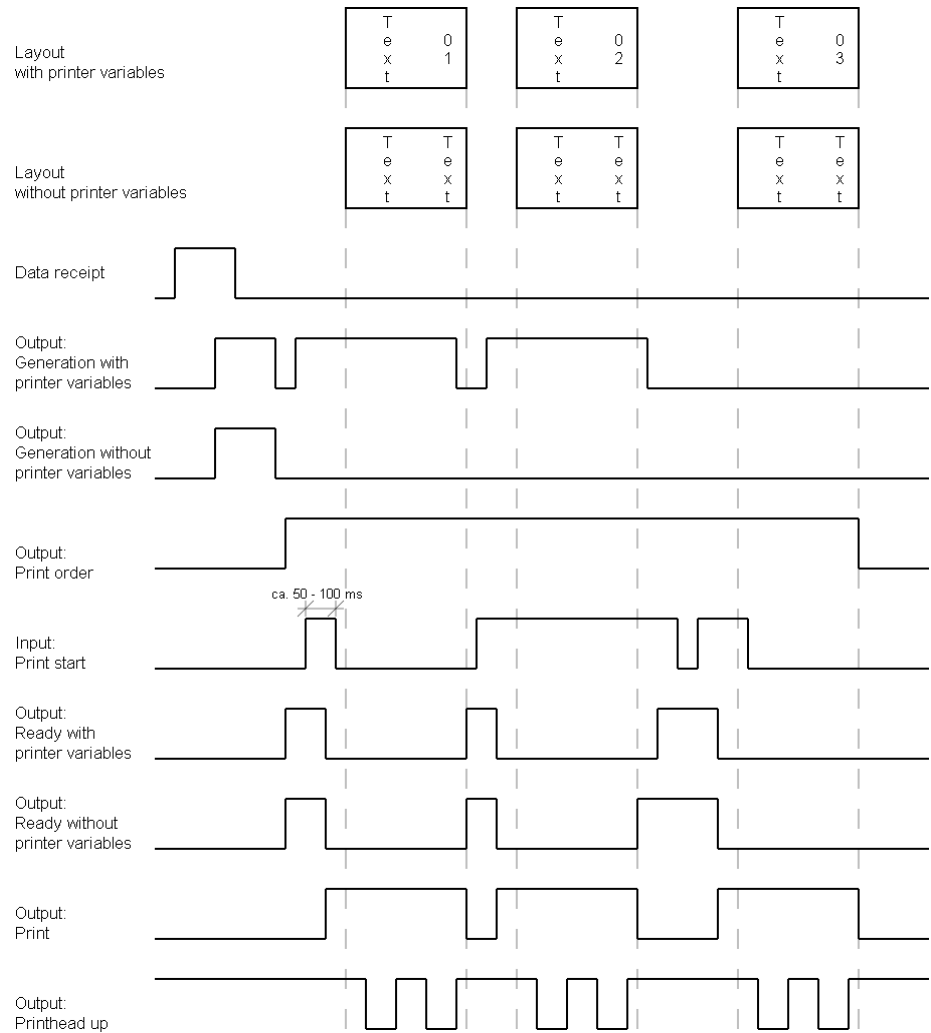

Layout/generation with module variables

The use of printer variables means that each layout is different and the direct print module has to generate several parts of the layout anew, e.g. variable counter.

Layout/generation without module variables

Each of the 3 layouts which are to print are the same and therefore it is only necessary to generate the layout once.

Data receipt

Because only 1 print order is send, the direct print module has only to receive once.

Print order

As the print order consists of three layouts, the print order output is active as long as all 3 layouts are printed.

Print start/print

In dispenser mode dynamic only the slope of the start impulse is recognised as valid print start signal. However, the impulse should have a minimum impulse width of 50 ms.

Dispenser Mode: Static

Number of layouts per print order: 4
 Data memory: Off/standard/extended
 Ribbon save: On
 Trigger input print start: level High

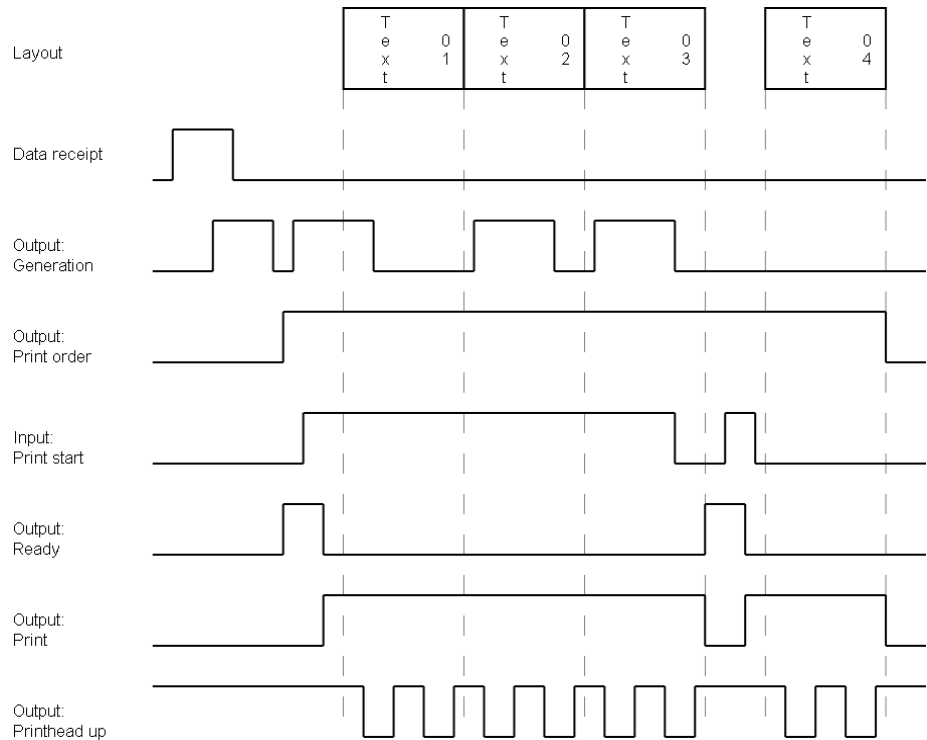
**Layout**

4 layouts with counter.

Print start/print

In 'dispenser mode: static' the level of the start impulse is recognised as valid start signal. In case the level is activated then the print is continued immediately if the following layout is already generated. After deleting the signal, the machine prints until the end of the current layout and then the direct print module waits for the next start impulse.

10.2 Intermittent Mode

Single item processing

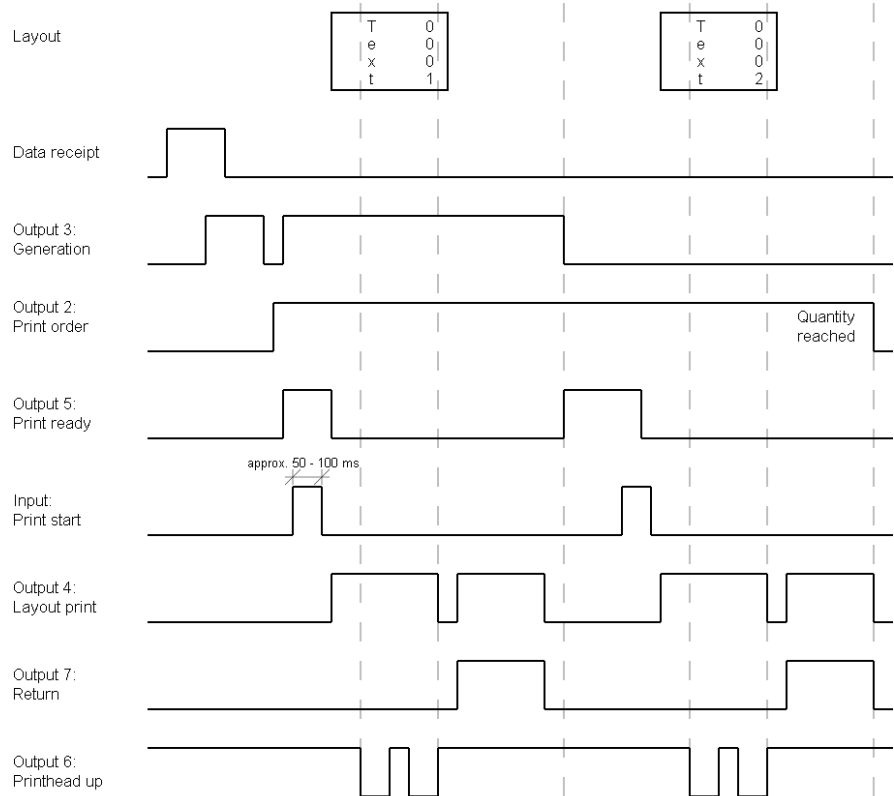

Continuous mode

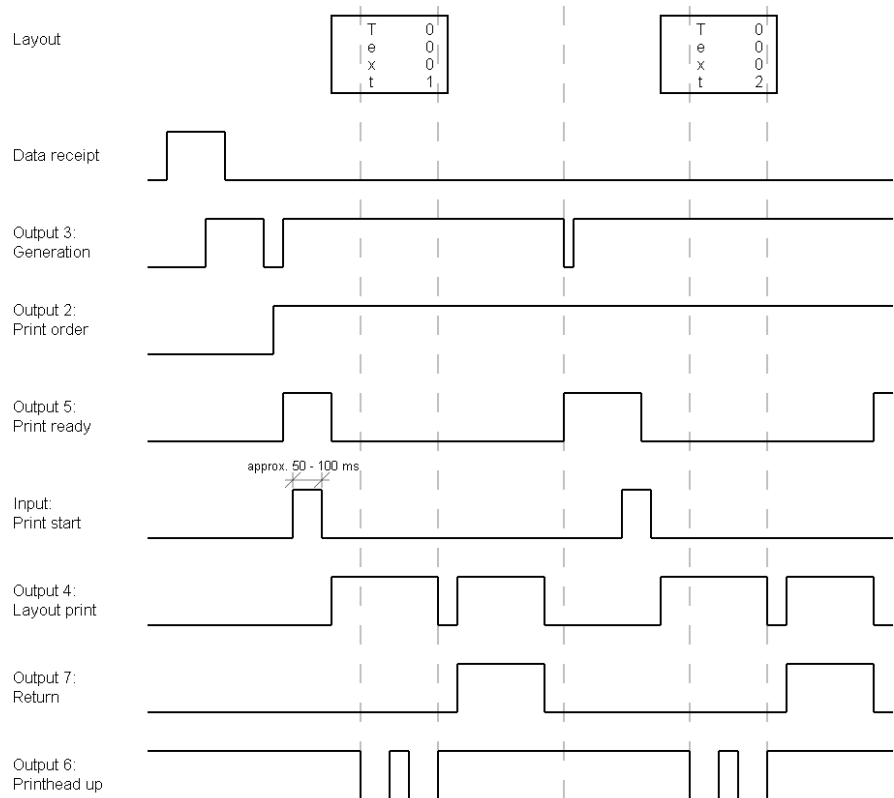

11 Error Correction

Error message	Cause	Remedy
1 Line too high	Line rises up completely or partly over the upper edge of label.	Move line down (increase Y value). Check rotation and font.
2 Line too low	Line rises up completely or partly over the bottom edge of label.	Move line up (reduce Y value). Check rotation and font.
3 Character set	One res. several characters of the text is res. are not available in the selected font.	Change text. Change font.
4 Unknown BC type	Selected code is not available.	Check code type.
5 Illegal rotation	Selected rotation is not available.	Check rotation.
6 CV font	Selected font is not available.	Check font.
7 Vector font	Selected font is not available.	Check font.
8 Measuring label	While measuring no label was found. Set label length is too large.	Check label length and if labels are inserted correctly. Restart measuring anew.
9 No label found	No label available. Soiled label photocell. Labels not inserted correctly.	Insert new label roll. Check if labels are inserted correctly. Clean the label photocell.
10 No ribbon	During the print order the ribbon roll becomes empty. Defect at the transfer ribbon photocell.	Change transfer ribbon. Check transfer ribbon photocell (service functions).
11 COM FRAMING	Stop bit error.	Check stop bits. Check baud rate. Check cable (printer and PC).
12 COM PARITY	Parity error.	Check parity. Check baud rate. Check cable (printer and PC).
13 COM OVERRUN	Loss of data at serial interface (RS-232).	Check baud rate. Check cable (printer and PC).

Error message	Cause	Remedy
14 Field number	Received line number is invalid.	Check sent data. Check connection PC - printer.
15 Length mask	Invalid length of received mask statement.	Check sent data. Check connection PC - printer.
16 Unknown mask	Transferred mask statement is invalid.	Check sent data. Check connection PC - printer.
17 Missing ETB	No end of data found.	Check sent data. Check connection PC - printer.
18 Invalid character	One res. several characters of the bar code is res. are not valid.	Change bar code data. Change font.
19 Invalid statement	Unknown transferred data record.	Check sent data. Check connection PC - printer.
20 Invalid check digit	For check digit control the entered res. received check digit is wrong.	Calculate check digit anew. Check code data.
21 Invalid SC code	Selected SC factor is invalid for EAN res. UPC.	Check SC factor.
22 Invalid number of digits	Entered digits for EAN res. UPC are invalid < 12; > 13.	Check number of digits.
23 Type check digit	Selected check digit calculation is not available in the bar code.	Check calculation of check digit. Check bar code type.
24 Invalid extension	Selected zoom factor is not available.	Check zoom factor.
25 Offset sign	Entered sign is not available.	Check offset value.
26 Offset value	Entered offset value is invalid.	Check offset value.
27 Printhead temperature	Printhead temperature is too high. Defective printhead sensing device.	Reduce contrast. Change printhead.
28 Cutter error	With cut an error occurred. Paper jam.	Check label run. Check cutter run.

Error message	Cause	Remedy
29 Invalid parameter	Entered data do not correspond to the characters allowed from the application identifier.	Check code data.
30 Application Identifier	Selected application identifier is not available in GS1-128.	Check code data.
31 HIBC definition	Missing HIBC system sign. Missing primary code.	Check definition of HIBC code.
32 System clock	Real Time Clock function is selected but the battery is empty. Defective RTC.	Change battery. Change RTC component.
33 No CF interface	Interrupted connection CPU - CF card. Defective CF card interface.	Check connection CPU - CF card interface. Check CF card interface.
34 No print memory	Not enough print memory available.	Check CF assembly on CPU.
35 Cover open	The cover hood is open.	Close the hood.
36 BCD invalid format	BCD error Invalid format for the calculation of Euro variable.	Check entered format.
37 BCD overflow	BCD error Invalid format for the calculation of Euro variable.	Check entered format.
38 BCD division	BCD error Invalid format for the calculation of Euro variable.	Check entered format.
39 FLASH ERROR	Flash component error.	Run a software update. Change CPU.
40 Length command	Invalid length of the received command statement.	Check data sent. Check connection PC - printer.
41 No drive	CF card not found / not correctly inserted.	Insert CF card correctly.
42 Drive error	Impossible to read CF card (faulty).	Check CF card, if necessary change it.
43 Unformatted	CF Card not formatted.	Format CF card.

Error message	Cause	Remedy
44 Delete directory	Attempt to delete the actual directory.	Change directory.
45 Invalid path	Too long indication of path.	Indicate a shorter path.
46 Drive write-protected	Memory card is write-protected.	Deactivate write protection.
47 Directory not file	Attempt to indicate a directory as file name.	Correct your entry.
48 File already open	Attempt to change a file during an access is active.	Select another file.
49 No file/directory	File does not exist on CF card.	Check file name.
50 Invalid file name	File name contains invalid characters.	Correct entry of name, remove special characters.
51 Internal file error	Internal file system error.	Please contact your distributor.
52 Root full	The max. number (64) of main directory entries is reached.	Delete at least one main directory entry and create subdirectories.
53 Drive full	Maximum CF capacity is reached.	Use new CF Card, delete no longer required files.
54 File/directory exists	The selected file/directory already exists.	Check name, select a different name.
55 File too large	During copying procedure not enough memory space onto target drive available.	Use a larger target card.
56 No update file	Errors in update file of firmware.	Start update file anew.
57 Invalid graphic file	The selected file does not contain graphic data.	Check file name.
58 Directory not empty	Attempt to delete a not empty directory.	Delete all files and sub-directories in the desired directory.
59 No CF interface	No CF card drive found.	Check connection of CF card drive. Contact your distributor
60 No media	No CF card is inserted.	Insert CF card in the slot.
61 Webserver error	Error at start of web server.	Please contact your distributor.

Error message	Cause	Remedy
62 Wrong PH FPGA	The direct print module is equipped with the wrong FPGA.	Please contact your distributor.
63 End position	The label length is too long. The number of labels per cycle is too much.	Check label length res. the number of labels per cycle.
64 Zero point	Defective photocell.	Change photocell.
65 Compressed air	Pressure air is not connected.	Check pressure air.
66 External release	External print release signal is missing.	Check input signal.
67 Column too wide	Wrong definition of column width res. number of columns.	Reduce the column width res. correct the number of columns.
68 Scanner	The connected bar code scanner signals a device error.	Check the connection scanner/printer. Check scanner (dirty).
69 Scanner NoRead	Bad print quality. Printhead completely soiled or defective. Print speed too high.	Increase contrast. Clean printhead or exchange (if necessary). Reduce print speed.
70 Scanner data	Scanned data does not correspond to the data which is to print.	Exchange printhead.
71 Invalid page	As page number either 0 or a number > 9 is selected.	Select a number between 1 and 9.
72 Page selection	A page which is not available is selected.	Check the defined pages.
73 Undefined page	The page is not defined.	Check the print definition.
74 Format user guiding	Wrong format for customized entry.	Check the format string.
75 Format date/time	Wrong format for date/time.	Check the format string.
76 Hotstart CF	No CF card found.	If option hotstart was activated, a CF card must be inserted. Switch off the printer before inserting the memory card.
77 Flip/Rotate	Selection of print of several columns and also mirror/rotate.	It is only possible to select one of both functions.

Error message	Cause	Remedy
78 System file	Loading of temporary hotstart files.	Not possible.
79 Shift variable	Faulty definition of shift times (overlapping times).	Check definition of shift times.
80 GS1 Databar	General GS1 Databar error.	Check definition and parameter of GS1 Databar code.
81 IGP error	Protocol error IGP.	Check sent data.
82 Time generation	Printing creation was still active at print start.	Reduce print speed. Use printers' output signal for synchronization. Use bitmap fonts to reduce generating time.
83 Transport protection	Both DPM position sensors (start/end) are active.	Displace zero point sensor Check sensors in service functions menu
84 No font data	Font and web data is missing.	Run a software update.
85 No layout ID	Layout ID definition is missing.	Define layout ID onto the label.
86 Layout ID	Scanned data does not correspond to defined ID.	Wrong label loaded from CF card.
87 RFID no label	RFID unit cannot recognize a label.	Displace RFID unit or use an offset.
88 RFID verify	Error while checking programmed data.	Faulty RFID label. Check RFID definitions
89 RFID timeout	Error at programming the RFID label.	Label positioning. Faulty label.
90 RFID data	Faulty or incomplete definition of RFID data.	Check RFID data definitions.
91 RFID tag type	Definition of label data does not correspond with the used label.	Check storage partitioning of used label type
92 RFID lock	Error at programming the RFID label (locked fields).	Check RFID data definitions. Label was already programmed.
93 RFID programming	Error at programming the RFID label.	Check RFID definitions.

Error message	Cause	Remedy
94 Scanner timeout	The scanner could not read the bar code within the set timeout time.	
	Defective printhead. Wrinkles in transfer ribbon. Scanner wrong positioned. Timeout time too short.	Check printhead. Check transfer ribbon. Position scanner correctly, corresponding to the set feeding. Select longer timeout time.
95 Scanner layout difference	Scanner data does not correspond to bar code data.	Check adjustment of scanner. Check scanner settings / connection.
96 COM break	Serial interface error.	Check settings for serial data transmission as well as cable (printer-PC).
97 COM general	Serial interface error.	Check settings for serial data transmission as well as cable (printer-PC).
98 No software printhead FPGA	No printhead-FPGA data available.	Please contact your responsible distributor.
99 Load software printhead FPGA	Error when programming printhead-FPGA.	Please contact your responsible distributor.
100 Upper position	Option applicator Sensor signal up is missing.	Check input signals / compressed-air supply.
101 Lower position	Option applicator Sensor signal down is missing).	Check input signals / compressed-air supply.
102 Vacuum plate empty	Option applicator Sensor does not recognize a label at vacuum plate).	Check input signals / compressed-air supply.
103 Start signal	Print order is active but device not ready to process it.	Check start signal.
104 No print data	Print data outside the defined label. Selection of wrong module type (design software).	Check selected module type. Check selection of left/right version.
105 Printhead	No original printhead is used.	Check the used printhead. Contact your distributor.

Error message	Cause	Remedy
106 Invalid Tag type	Wrong Tag type. Tag data do not match the Tag type in the printer.	Adapt data or use the correct Tag type.
107 RFID inactive	RFID module is not activated. No RFID data can be processed.	Activate RFID module or remove RFID data from label data.
108 GS1-128 invalid	Transferred GS1-128 bar code is invalid.	Verify bar code data (see GS1-128 bar code specification).
109 EPC parameter	Error at EPC calculation.	Verify data (see EPC specification).
110 Housing open	When starting the print order the housing cover is not closed.	Close the housing cover and start the print order anew.
111 EAN.UCC code	Transferred EAN.UCC code is invalid.	Verify bar code data (see corresponding specification).
112 Print carriage	Printing carriage does not move.	Check gear belt (possibly broken).
113 Applicator error	Option applicator Error while using applicator.	Check applicator.
114 Left position	Option applicator Left final position switch is not in correct position.	Check LEFT final position switch for correct function and position. Check function of pneumatics for cross traverse.
115 Right position	Option applicator Right final position switch is not in correct position.	Check RIGHT final position switch for correct function and position. Check function of pneumatics for cross traverse.
116 Print position	Option applicator: The applicator is not in the print position when trying to print a label.	Check TOP and RIGHT final position switch for correct function and position. Check pneumatics for function
117 XML parameter	The parameters in the XML file are not correct.	Please contact your responsible distributor.
118 Invalid variable	Transferred variable is invalid with customized entry.	Select correct variable without customized entry and transfer it.

Error message	Cause	Remedy
119 No ribbon	During the print order the ribbon roll becomes empty. Defect at the transfer ribbon photocell.	Change transfer ribbon. Check transfer ribbon photocell (service functions).
120 Wrong directory	Invalid target directory when copying.	Target directory must not be within the source directory. Check target directory.
121 No label PH2	No label found at the rear printhead (DuoPrint). Soiled label photocell. Labels not inserted correctly.	Insert new label roll. Clean the label photocell. Check if labels are inserted correctly.
122 IP occupied	The IP address was already assigned.	Assign a new IP address.
123 Print asynchronous	The label photocell do not work in the order as it is expected according to print data. The settings of the photocell are not correct. Settings of label size and gap size are not correct. No label found at the rear printhead. Soiled label photocell. Labels not inserted correctly.	Check label size and gap size. Check label photocell settings. Check correct loading of label material. Insert new label roll. Clean the label photocell. Check if labels are inserted correctly.
124 Speed too low	Print speed is too slow.	Increase the speed of customers' machine.
125 DMA buffer	Communication problem HMI.	Restart the printer.
126 UID conflict	Configuration RFID programming faulty.	Run RFID initialising.
127 Module not found	RFID module not available.	Check the RFID module connection. Please contact your responsible distributor.
128 No release signal	No print release by higher-level control (customer machine).	Activate release signal at the higher-level control.

Error message	Cause	Remedy
129 Wrong firmware	Firmware does not match the used printer type.	Use firmware that fits to the printer type. Please contact your responsible distributor.
130 Language missing	Language file for the set printer language is not available.	Please contact your responsible distributor.
131 Wrong material	Label material does not fit to printing data.	User label material with suitable label and/or gap length.
132 Invalid mark-up tag	Invalid mark-up formatting characters in text.	Correct the formatting characters in the text.
133 Script not found	LUA script file not found.	Check the file name.
134 Script failure	LUA script is incorrect.	Check the script.
135 Script user error	Error in LUA script user input.	Correct the input value.
136 No reprint available	No label data for reprinting available.	Send new label data to the printer.
137 Printhead short circuit	Electrical short at the printhead.	Check the used printhead. Please contact your distributor.
138 Too less ribbon	Transfer ribbon ends.	Change transfer ribbon.
139 Rewinder error	Label band is torn	Load a new label roll. Stick together the label band.
140 Rewinder motor blocked	External rewinder motor is blocked.	Switch off the printing system and check mechanical resistance. Change the full label roll.
141 Hardware error	A hardware component could not be found.	Please contact your responsible distributor.
142 No print mechanics	No print mechanics connected.	Check connection (print mechanics – control unit)
143 Printhead sensor	No signal change at the printhead photocell.	Check printhead photocell for proper functioning.
144 FreeType error	Problem with generating TrueType text.	Check print data.

Error message	Cause	Remedy
145 -	Reserved	reserved
146 Unknown (see Log)	Internal error.	Check log files or send them to support.
147 Upper sensor	Upper limit sensor defective.	Check or replace the upper limit sensor.
148 Parameter	Parameter incorrectly formatted.	Check parameters.
149 QR code invalid	Invalid QR code parameters.	Check QR code parameters.
150 Short PH motor	Short circuit in the printhead motor.	Check printhead motor.
151 Wire PH motor	Wire break at the printhead motor.	Check the printhead motor connection.
152 Short TR motor	Short circuit in the transfer ribbon motor.	Check transfer ribbon motor.
153 Wire TR motor	Wire break at the transfer ribbon motor.	Check the transfer ribbon motor connection.

12 Additional Information

12.1 Column Printing

With this direct print module several columns can be printed, i.e. the information of one column can be printed several times (depending on its width) on a layout. Caused by this the use of the complete print width is possible and the generating time is enormously reduced.

For example four columns with a width of 25 mm or two columns with a width of 50 mm can be printed onto a layout with a width of 100 mm. Please note that the first layout is always the one with the largest x coordinate, i.e. it has the largest distance to the printhead.

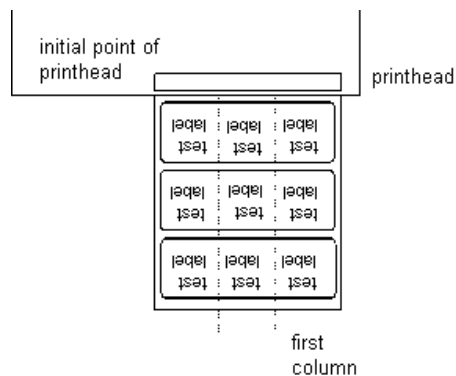



Setting the print of several columns



Press the key **F** to access the function menu.



Press the key  until the menu *Layout* is displayed.

Press the key  to confirm the selection.

Press the key  until the menu item *Width/Columns* is displayed.

Press the keys  and  to set the layout width. The *Width* is the width of one column, e.g. 20.0 mm.

Press the keys  and  to move to the *Column* input field.

Press the keys  and  to change the number of columns, e.g. four columns with a layout width of 20.0 mm.

Press the key  to start the print with input of number of layouts and number of lines. The number of layouts corresponds to the number of layouts that should be printed.
e.g. Columns: 3, Items: 4

label 6	label 5	label 4
label 3	label 2	label 1

The first four layouts were printed but not layouts 5 and 6.

12.2 Hotstart



NOTICE!

The data is saved onto CF card. Therefore the CF card is a condition for the *Hotstart* menu item.

The function *Hotstart* contains e.g. that in case of a power failure the currently loaded layout can be further processed without any loss of data. Moreover a print order can be interrupted and to be continued after switching on the direct print module anew.



NOTICE!

At an active *Hotstart* all necessary data is stored on the CF card therefore do not remove the card during operation. When removing during operation, this causes the loss of all data on the CF card.

Save current layout

In case the *Hotstart* function is set to on, at the start of a print order the data of the current layout is saved to the corresponding directory of the CF card.

However the following conditions have to be fulfilled:

- CF card inserted in drive A.
- CF card not write-protected.
- Enough free storage space onto CF card.

An error message appears in case these conditions are not fulfilled.

Save print order state

At switching off the direct print module the state of the current print order is saved to the corresponding directory of the CF card.

However the following conditions have to be fulfilled:

- CF card inserted in drive A.
- CF card not write-protected.
- Enough free storage space onto CF card.

Load layout and print order state

When restarting the direct print module (if the function *Hotstart* is activated) the saved layout data and the status of print order were loaded from the corresponding file on the CF card. Because of this reason, when switching on the direct print module a CF card has to be inserted in the appropriate drive. If the data cannot be loaded an error message appears.

Start print order

In case at switching off the direct print module a print order was active, then a print start is released automatically and the required res. actual number of printed layouts is refreshed. In case the print order was stopped at switching off the direct print module, it is again set to the stopped mode after switching on the direct print module anew. In case a customized entry was active during switching off the direct print module, the window for the first customized variable is displayed.

Refresh variable counter

As in the intended file only the start values of the counter are saved, they are refreshed at a new start of the print order by means of the number of printed layouts. Each counter is counted corresponding from its start value. Afterwards the position of the current and the next counter update are correctly set by means of the update intervals.

**NOTICE**

Make sure that in case graphics are onto the layout they have to be saved onto CF card.

13 Environmentally-Friendly Disposal

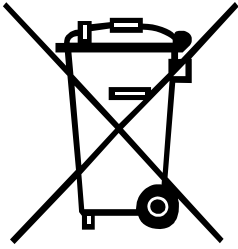

Manufacturers of B2B equipment are obliged to take back and dispose of old equipment that was manufactured after 13 August 2005. As a principle, this old equipment may not be delivered to communal collecting points. It may only be organised, used and disposed of by the manufacturer. Valentin products accordingly labelled can therefore be returned to Carl Valentin GmbH.

This way, you can be sure your old equipment will be disposed of correctly.

Carl Valentin GmbH thereby fulfils all obligations regarding timely disposal of old equipment and facilitates the smooth reselling of these products. Please understand that we can only take back equipment that is sent free of carriage charges.

The electronics board of the printing system is equipped with a battery. This must only be discarded in battery collection containers or by public waste management authorities.

Further information on the WEEE directive is available on our website www.carl-valentin.de.

14 Index

C

clamping force (ribbon roll), increase	39
column printing	115
compact flash card	
change directory	83
copying	87
define user directory	81, 82
delete file	85
display structure	79
filter	88
firmware update	88
formatting	86
Load file	84
load layout	82
navigation	80
save configuration	85
save layout	84
connecting	36
connections, control unit	11
connections, print mechanics	10
continuous mode	
material guiding	12
material speed	12
print principle	12
control inputs/control outputs	21, 22, 24, 25, 26, 27, 28, 29

D

decommissioning/dismantling	7
display during printing	78

E

encoder, pin assignment	30
environmentally-friendly disposal	119
error messages/error corrections	103, 104, 105, 106, 107, 108, 109, 110, 111, 112, 113

F

function menu	
date/time	74
device settings	64, 65, 66
emulation	73
interface	72
IO parameters	67, 68
layout	56

machine parameters (continuous mode)	52, 53, 54
machine parameters (intermittent mode).....	54, 55
main menu	78
network	68, 69, 70
password	70, 71
print settings	51
ribbon save	57
ribbon save (continuous mode)	58, 59, 60, 61
ribbon save (intermittent mode).....	62, 63
service functions	75, 76, 77
H	
hotstart.....	116, 117
I	
initial operation	37
initial operation, preparations	36
installation at machines	32
instructions	5
intended use	5, 6
intermittent mode	
print position	13
print principle	13
K	
keyboard	
standard	41
text entry/user guiding	42, 43
M	
machine overview.....	9
maintenance/cleaning	
angle adjustment	94
cycle optimisation	96
general cleaning	90
print quality optimisation	95
printhead, cleaning	91
printhead, replacing	92, 93
ribbon drawing roller, cleaning.....	90
schedule	89
menu structure	
continuous mode	45, 46, 47
intermittent mode	48, 49, 50
O	
operating conditions	15, 16, 17

P	
pneumatic power supply, connecting	34
pressure power, adjusting	35
print control.....	37
print unit, front	10
S	
safety instructions.....	6, 7
scope of delivery	31
signal diagrams	
continuous mode	97, 98, 99, 100
intermittent mode	101
space, cable outgoing	33
T	
technical data	19, 20
transfer ribbon, loading.....	38
U	
unpacking	31
USB stick	
change directory	83
copying.....	87
delete file	85
display structure.....	79
filter	88
firmware update	88
load file.....	84
load layout	82
navigation	80
save configuration.....	85
save layout.....	84



Carl Valentin GmbH
Neckarstraße 78 – 86 u. 94
78056 Villingen-Schwenningen
Phone +49 7720 9712-0
info@carl-valentin.de
www.carl-valentin.de

