

## Encoder for ILX V

### General

The print modules of the ILX V series have been extended with an encoder connection. This makes the ILX V significantly easier to integrate into packaging lines, especially when using the so-called wipe-on process.

### Function

In the so-called Wipe-on method (see figure), the labels are separated from the backing material at a dispensing tongue and are applied directly onto the product to be labelled. A rubber roller or brush then ensures that the label is pressed evenly onto the passing product.



#### NOTICE!

To prevent wrinkling, it is crucial that the feed speed of the label (ILX V: feed speed = print speed) is synchronized with the conveyor speed of the product.

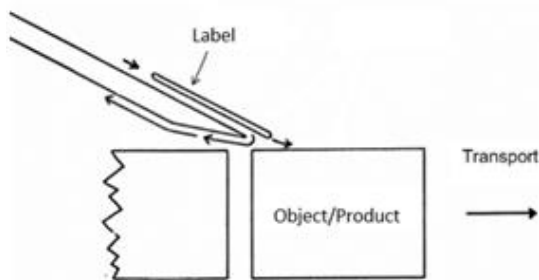

Wipe-On process

Typically, the label feed or the printing process is triggered by a product sensor (part no. 90.52.796B). With the ILX V, the sensor can be connected directly.

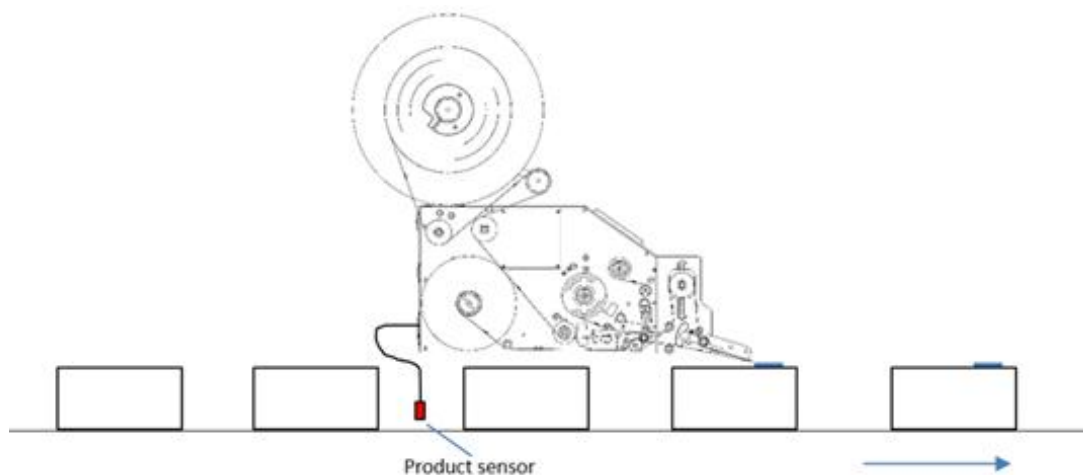

### Adjustment of Feed Speed/Print Speed

To prevent wrinkling during label application, the feed/print speed must be adjusted to match the product's conveyor speed. Previously, this adjustment was carried out manually via the ILX V menu or through corresponding settings in the label data. In cases of varying conveyor speeds, for example with different products, this results in increased setup effort as well as a higher risk of errors due to incorrect or forgotten settings.

The encoder automatically adjusts the print/feed speed to the conveyor speed. The current conveyor speed is continuously recorded and transmitted to the ILX V in real time. The ILX V independently adjusts the print/feed speed by selecting the next lower available speed value.

**Example:** Measured conveyor speed: 156 mm/s  
Set print speed: 150 mm/s

If the measured conveyor speed exceeds the maximum print speed of the ILX V (400 mm/s), the maximum value is used. If the conveyor speed falls below the minimum permissible value of 50 mm/s, adjustment to the conveyor speed is still carried out. However, in this range, consistently stable print quality can no longer be guaranteed.

### Print Offset

The product sensor is positioned at a defined distance from the dispensing edge. If the conveyor speed changes, the position of the applied label on the product also changes. Without the use of an encoder, the product sensor position must be manually readjusted or shifted accordingly to achieve the desired label position. To eliminate this additional effort for the user, the distance between the product sensor and the dispensing edge can be defined in the ILX V menu. Using the encoder, the system detects the actual distance covered by the product and can thus adjust the print timing accordingly. In basic mode (see section 'Adjusting the print speed'), this value must be manually adjusted when the conveyor speed changes. In encoder mode (see section 'Adjusting the print speed and start position'), however, the print timing is adjusted automatically depending on the conveyor speed. Please note that the print offset must not be set so large that two products are ever simultaneously located between the product sensor and the dispensing edge.

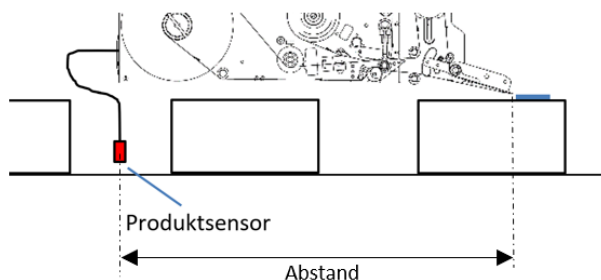

#### NOTICE!

The accuracy of the label position on the product is influenced by additional factors. This includes the distance between the dispensing tongue and the product, which must be adjusted depending on the label size and product characteristics. As a result, even when using an encoder, minor positional deviations may occur when the conveyor speed changes.

**Example:** Distance product sensor – Dispensing tongue: 200 mm  
When the conveyor speed changes from 150 mm/s to 200 mm/s, the label position on the product shifts by 66 mm.

## Encoder Operating Modes

The ILX V offers two different operating modes to optimally cover a wide range of applications.

### Adjusting the Print Speed

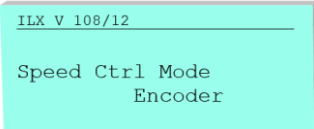
A screenshot of a control panel interface. At the top, it reads 'ILX V 108/12' followed by a horizontal line. Below the line, the text 'Speed Ctrl Mode' is displayed, and 'Encoder' is displayed below that.

```
ILX V 108/12
-----
Speed Ctrl Mode
Encoder
```

The encoder continuously measures the conveyor speed. During an active print process, the print speed is automatically adjusted as described above.

### Adjusting the Print Speed and the Start Position

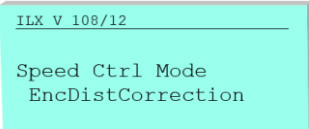
A screenshot of a control panel interface. At the top, it reads 'ILX V 108/12' followed by a horizontal line. Below the line, the text 'Speed Ctrl Mode' is displayed, and 'EncDistCorrection' is displayed below that.

```
ILX V 108/12
-----
Speed Ctrl Mode
EncDistCorrection
```

The speed adjustment functions as described above. In addition, this mode extends the functionality by enabling speed compensation of the print offset. The displacement of the label on the product is compensated by modifying the conveyor speed. To use this function, the print offset must be set to at least 20 mm. However, compensation is only possible within a limited range. The print offset must be sufficiently large to compensate for changes in conveyor speed. Mechanical settings, product characteristics, and the labels used also influence positioning accuracy.

## Connection of the Encoders

### Right version

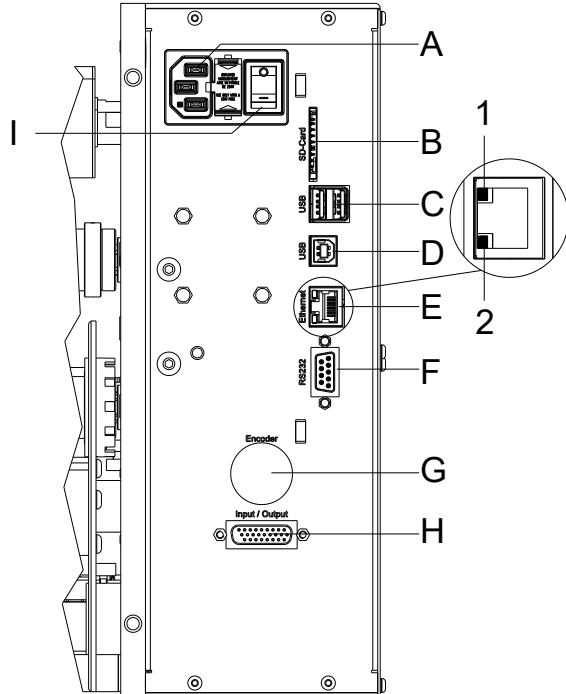

- A Power supply
- B Slot for SD card
- C 2 x USB host
- D USB interface
- E Ethernet 10/100
  - 1 = LED green
  - Lighting = Speed 100 Mbit
  - Off = Speed 10 Mbit
  - 2 = LED orange
  - Lighting = Connection active
  - Flashing = Data transfer
  - Off = No connection
- F Serial interface RS-232
- G Encoder connection (option)
- H External output/input
- I Power On/Off switch

### Left version

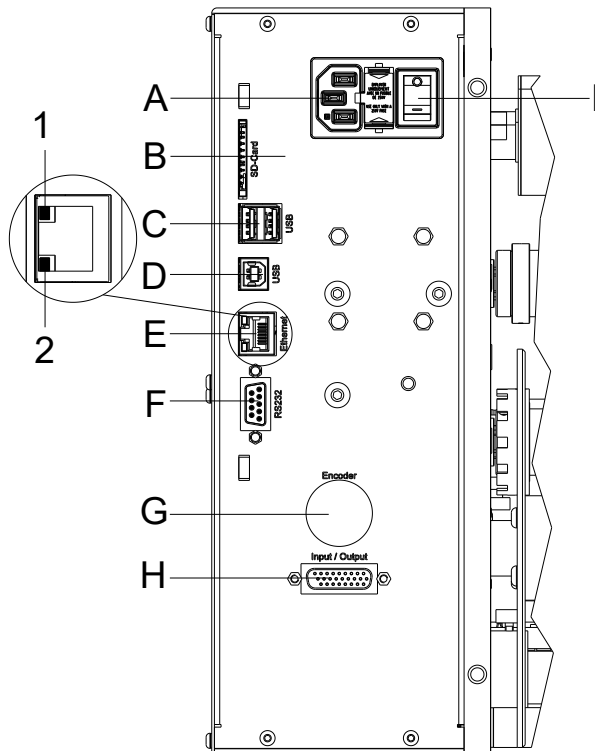

- A Power supply
- B Slot for SD card
- C 2 x USB host
- D USB interface
- E Ethernet 10/100
  - 1 = LED green
  - Lighting = Speed 100 MBit
  - Off = Speed 10 MBit
  - 2 = LED orange
  - Lighting = Connection active
  - Flashing = Data transfer
  - Off = No connection
- F Serial interface RS-232
- G Encoder connection (option)
- H External output/input
- I Power On/Off switch

## Pin Assignment Encoder Connection

5-pin connector socket; pin layout according to DIN 45322

connector socket  
encoder

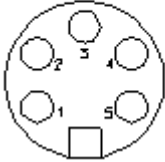

PIN1 = 5 VDC  
PIN2 = Encoder signal (channel A)  
PIN3 = Encoder signal (channel B)  
PIN4 = GND

The encoder interface provides both 5 V and 24 V for encoder power supply. For optimal results, we recommend using the encoder with part no. 90.67.706.

Version:	Standard
Supply voltage:	5 V
Flange/protection class/shaft:	Round/IP 64/6 mm
Output:	Push-pull output
Output:	Radial cable
Cable length:	2.5 m 4.5 m (part no. 90.67.708)

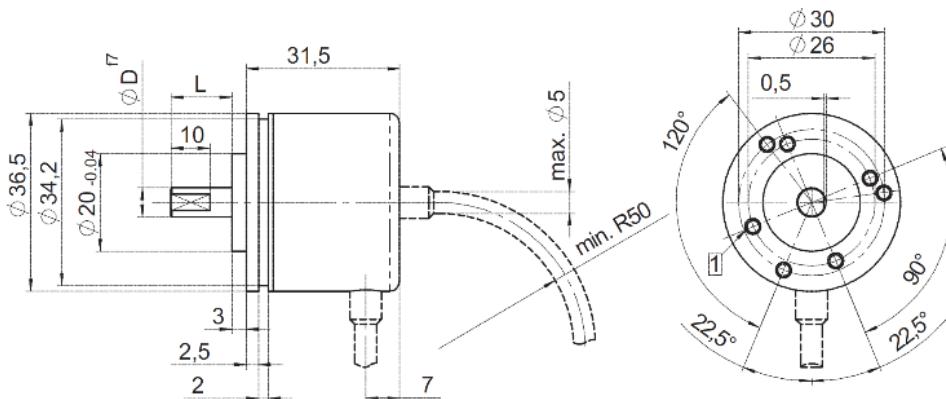

A friction wheel (part no. 72.67.550) can be mounted on the encoder to measure the conveyor speed directly from the conveyor belt, for example.



## Parameter Settings

In the ILX V menu, the encoder function must be activated and parameterized. The *Dispenser Operating Mode* must be set to *Dynamic*, after which the encoder can be activated in the corresponding menu item.

After switching on the printing system, the main menu is displayed.

Press the key **F** to access the *Function Menu*.

Press the key  until the menu *Dispenser I/O* is displayed.

Press the key  to select the menu.

In the top line of the display, the operating mode is indicated.

Press the key  to switch to the *Dynamic* mode.

Press the key  to confirm the selection.

Press the key **F** to return to the menu *Device Settings*.

Press key  to select the menu.

Press the key  until the submenu *Start Behavior* is reached.

Press the key  to confirm the selection.

Press the key  until the menu item *Speed Ctrl Mode* is reached.

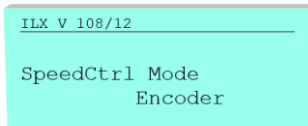

Press the key  to select *Encoder*.

Press the key  to confirm the selection.

In the function menu, press the key  until the menu *Encoder Parameter* is reached.

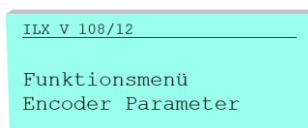

## Setting the Encoder Parameters

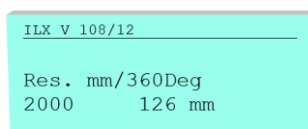

**Res. mm:** Encoder resolution (in the example: 2000 pulses/revolution).

**360Deg:** Product feed per encoder revolution, i.e. the distance covered per revolution.

**In the example:** The recommended friction wheel has a diameter of 40 mm, giving a circumference of 125.6 mm.

## Setting the Encoder Parameter

```
ILX V 108/12
-----
Print Offset
  100.0 mm
```

The ILX V delays the start signal triggered by the product sensor by the set travel distance. In the mode *Encoder with start position adjustment*, the label position on the product is kept constant regardless of the conveyor speed. A minimum input value of 2 mm is required.



### NOTICE!

Depending on label length, distance between dispensing tongue and the product, mechanical tolerances, and product characteristics, position deviations of up to 3 mm may still occur.

## Encoder Rotation Direction

A correctly defined encoder rotation direction is a prerequisite for using the functions. The encoder counter must count positively in the application direction during operation. Otherwise, the counting direction must be inverted.

## Optimization of Positioning

To achieve the most accurate possible positioning of the label on the product, the debounce time (debouncing) of the print start signal (product photocell) can be reduced to 0 ms, provided that no false start signals are triggered as a result.

For speed-dependent position correction, it must be ensured that the print offset (EncoderParameter->PrintOffset) is not less than 40 mm at a maximum conveyor or print speed of 400 mm/s.